

Service
Service
Service **Second Generation**



Service Manual

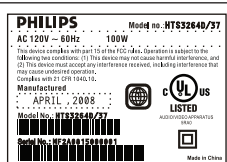

TABLE OF CONTENTS

	Chapter
Location of PCB Boards	1-2
Versions Variation	1-2
Specifications	1-3
Measurement Setup	1-4
Service Aids	1-5
ESD & Safety Instruction	1-6
Lead-free soldering Information	1-7
Setting procedure & Repair Instructions.....	2
Disassembly Instructions & Service positions	3
Block & Wiring Diagram	4
VFD+JACK+STANDBY Board	5
Main Board	6
Power Board	7
Mechanical Exploded View & Part List	8
Revision List	9

This service manual is for HTS3264D/37 Second Generation model, which is different from the previous generation HTS3264D/37 models.

For Second Generation model the serial number begin with MF2AXXXXXXXXXX. Refer to the rating label illustration at right.



© Copyright 2008 Philips Consumer Electronics B.V. Eindhoven, The Netherlands
All rights reserved. No part of this publication may be reproduced, stored in a retrieval system or transmitted, in any form or by any means, electronic, mechanical, photocopying, or otherwise without the prior permission of Philips.

Published by LM0833 Service Audio Printed in The Netherlands Subject to modification

GB 3139 785 34520

Version 1.0



PHILIPS

LOCATION OF PCB BOARDS

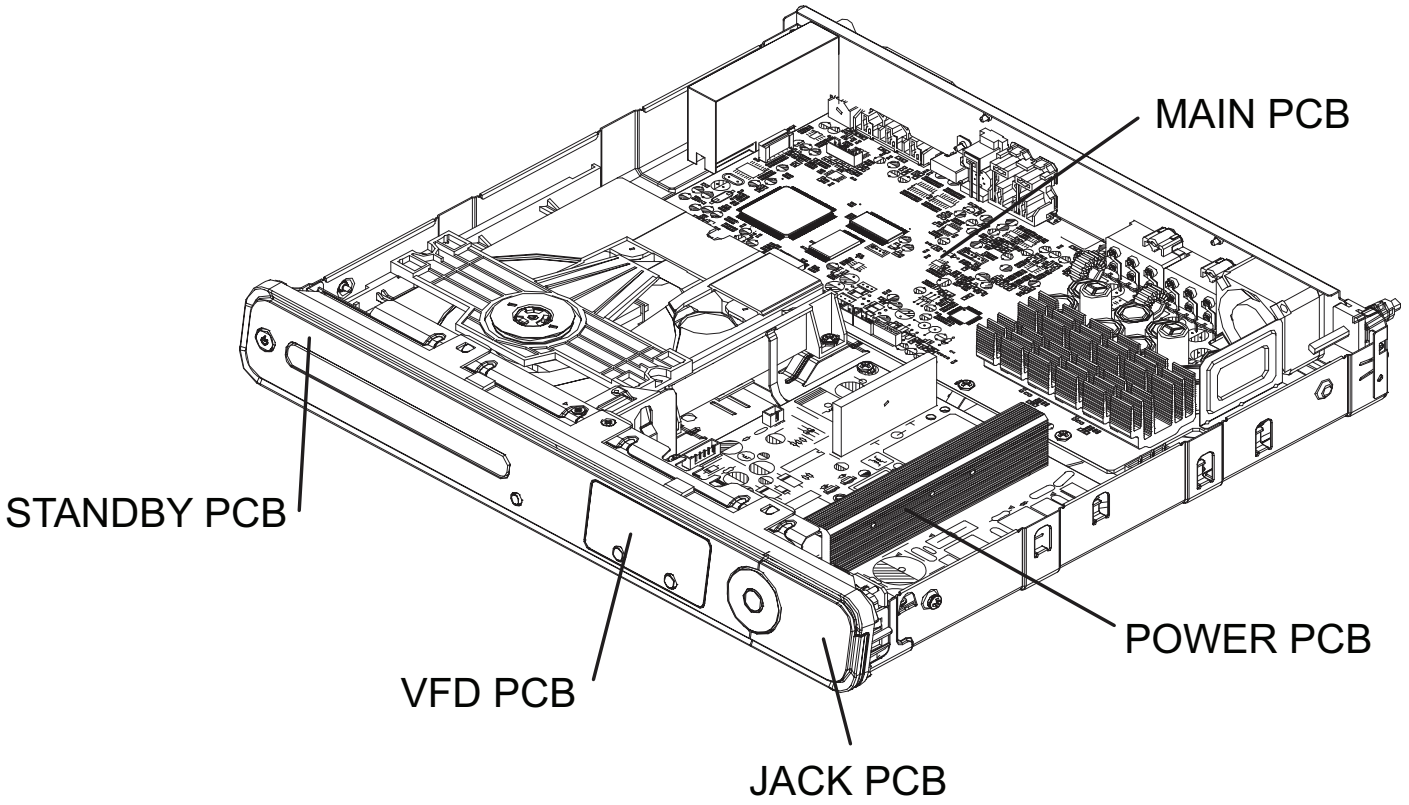

VERSION VARIATION:

Type/Versions	HTS3264D
Features	/37
Output Power - 600W	X
Voltage (120V)	X
Aux IN	X

SERVICE SCENARIO MATRIX:

Type/Versions	HTS3264D
Board in used	/37
Main Board	Bd
Power Board	Bd
VFD+JACK+STANDBY Board	Bd

*Bd = Board Level Repair

SPECIFICATIONS

AMPLIFIER

Total output power:	
- Home Theater mode	600 W
- FTC* output power	420 W
Frequency Response	180 Hz – 18 kHz / ±3 dB
Signal-to-Noise Ratio.....	> 60 dB (A-weighted)
Input Sensitivity	
- AUX 1	400 mV
- AUX 2	400 mV
- MP3 LINK	400 mV
* (Main Ch@1kHz Sub Ch 60 Hz within 1% THD)	

RADIO

Tuning Range.....	FM 87.5-108 MHz
.....	(100 kHz)
.....	26 dB Quieting
Sensitivity	FM 22 dBf
IF Rejection Ratio	FM 60 dB
Signal-to-Noise Ratio.....	FM 50 dB
Harmonic Distortion	FM Mono 3%
.....	FM Stereo 3%
Frequency Response	FM 180 Hz–10 kHz / ±6 dB
Stereo Separation.....	FM 26 dB (1 kHz)
Stereo Threshold.....	FM 29 dB

DISC

Laser Type.....	Semiconductor
Disc Diametre	12cm / 8cm
Video Decoding	MPEG-1 / MPEG-2 /
.....	/ DivX 3/4/5/6, Ultra
Video DAC	12 Bits
Signal System.....	NTSC / Multi
Video Format	4:3 / 16:9
Video S/N	56 dB
Composite Video	
Output.....	1.0 Vp-p, 75W
Frequency Response	4 Hz–20 kHz (44.1 kHz)
.....	4 Hz–22 kHz (48 kHz)
.....	4 Hz–44 kHz (96 kHz)
PCM.....	IEC 60958
Dolby Digital	IEC 60958, IEC 61937

MAIN UNIT

Power Supply Rating	120 V; 60 Hz
Power Consumption	100 W
Dimensions.....	360 x 58 x 332 (mm)
.....	(w x h x d)
Weight	2.9 kg

IPOD DOCK

Dimensions.....	32.5 x 104 (mm)
.....	(h x d)
Weight	163.5 g

FRONT AND REAR SPEAKERS

System.....	Full range satellite
Impedance.....	3W
Speaker drivers	3" full range speaker
Frequency response.....	150 Hz – 20 kHz
Dimensions.....	103 x 203 x 71 (mm)
.....	(w x h x d)
Weight	0.45 kg/each

CENTRE SPEAKER

System.....	Full range satellite
Impedance.....	6W
Speaker drivers	3" full range speaker
Frequency response.....	150 Hz – 20 kHz
Dimensions.....	244 x 105 x 74 (mm)
.....	(w x h x d)
Weight	0.78 kg

SUBWOOFER

Impedance.....	6 W
Speaker drivers	165mm (6.5") woofer
Frequency response.....	40 Hz – 150 Hz
Dimensions.....	123 x 310 x 369 (mm)
.....	(w x h x d)
Weight	3.85 kg

Specifications subject to change without prior notice.

MEASUREMENT SETUP

Tuner FM

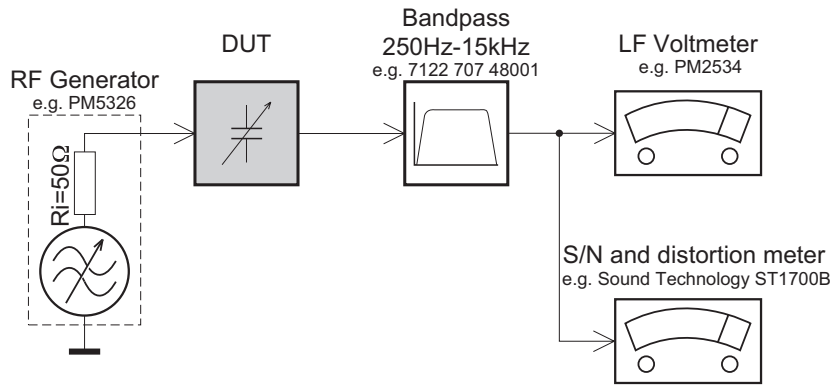

Use a bandpass filter to eliminate hum (50Hz, 100Hz) and disturbance from the pilotone (19kHz, 38kHz).

CD

Use Audio Signal Disc SBC429 4822 397 30184
(replaces test disc 3)

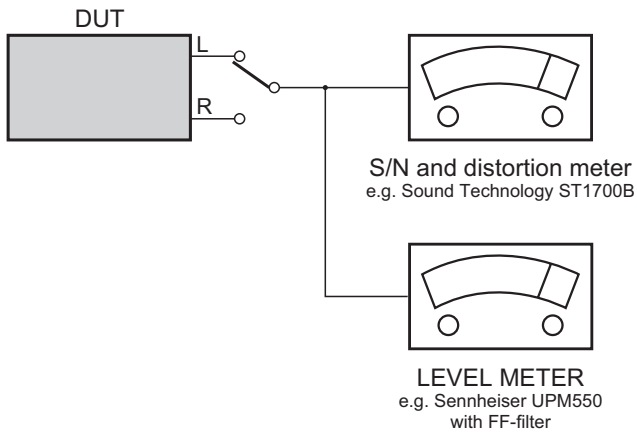

SERVICE AIDS

Service Tools:

Universal Torx driver holder	4822 395 91019
Torx bit T10 150mm	4822 395 50456
Torx driver set T6-T20	4822 395 50145
Torx driver T10 extended	4822 395 50423

Compact Disc:

SBC426/426A Test disc 5 + 5A	4822 397 30096
SBC442 Audio Burn-in test disc 1kHz	4822 397 30155
SBC429 Audio Signals disc	4822 397 30184
Dolby Pro-logic Test Disc	4822 395 10216

HANDLING CHIP COMPONENTS

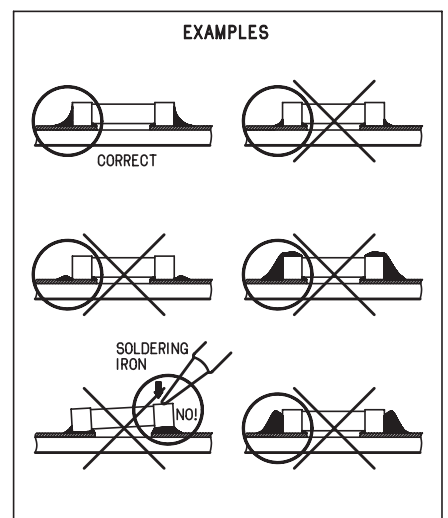
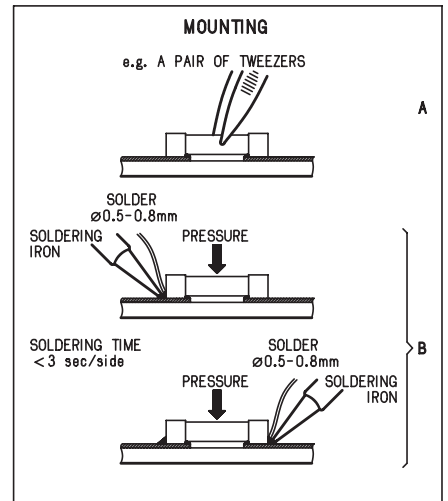
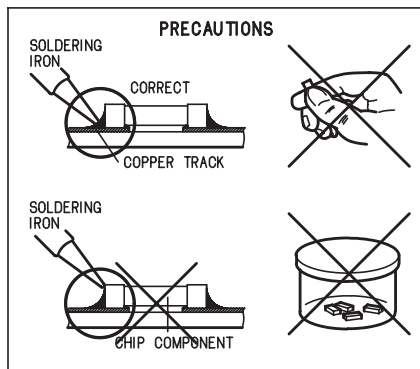
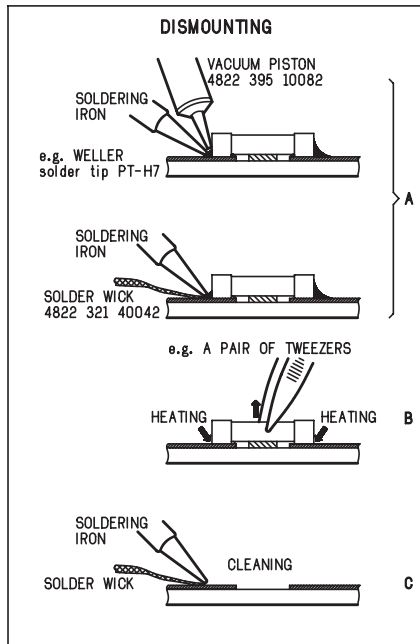
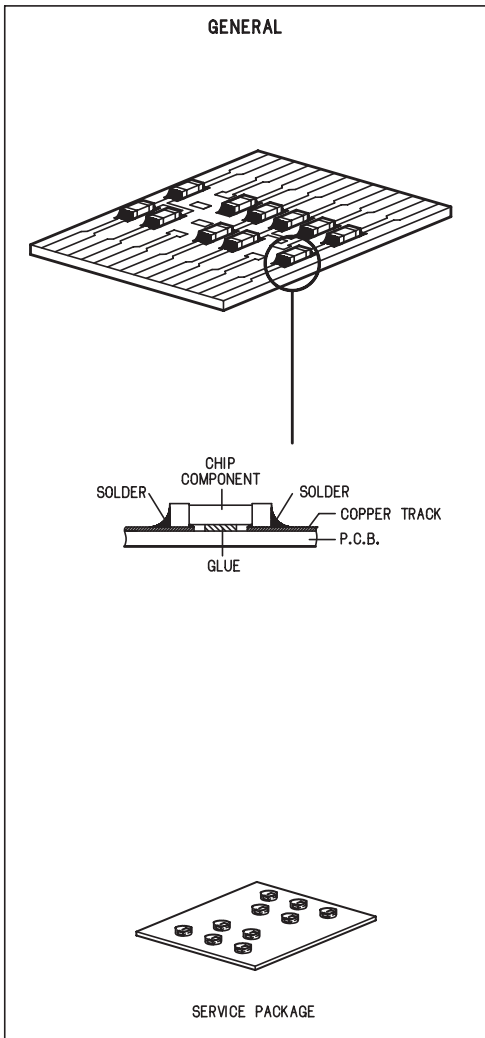

ESD**(GB) WARNING**

All ICs and many other semi-conductors are susceptible to electrostatic discharges (ESD). Careless handling during repair can reduce life drastically.

When repairing, make sure that you are connected with the same potential as the mass of the set via a wrist wrap with resistance. Keep components and tools also at this potential.

(F) ATTENTION

Tous les IC et beaucoup d'autres semi-conducteurs sont sensibles aux décharges statiques (ESD).

Leur longévité pourrait être considérablement écourtée par le fait qu'aucune précaution n'est prise à leur manipulation.

Lors de réparations, s'assurer de bien être relié au même potentiel que la masse de l'appareil et enfiler le bracelet serti d'une résistance de sécurité.

Veiller à ce que les composants ainsi que les outils que l'on utilise soient également à ce potentiel.

(D) WARNUNG

Alle ICs und viele andere Halbleiter sind empfindlich gegenüber elektrostatischen Entladungen (ESD).

Unvorsichtige Behandlung im Reparaturfall kann die Lebensdauer drastisch reduzieren. Veranlassen Sie, dass Sie im Reparaturfall über ein Pulsarmband mit Widerstand verbunden sind mit dem gleichen Potential wie die Masse des Gerätes.

Bauteile und Hilfsmittel auch auf dieses gleiche Potential halten.

(NL) WAARSCHUWING

Alle IC's en vele andere halfgeleiders zijn gevoelig voor electrostatische ontladingen (ESD).

Onzorgvuldig behandelen tijdens reparatie kan de levensduur drastisch doen verminderen. Zorg ervoor dat u tijdens reparatie via een polsband met weerstand verbonden bent met hetzelfde potentiaal als de massa van het apparaat.

Houd componenten en hulpmiddelen ook op ditzelfde potentiaal.

(I) AVVERTIMENTO

Tutti IC e parecchi semi-conduttori sono sensibili alle scariche statiche (ESD). La loro longevità potrebbe essere fortemente ridotta in caso di non osservazione della più grande cauzione alla loro manipolazione. Durante le riparazioni occorre quindi essere collegato allo stesso potenziale che quello della massa dell'apparecchio tramite un bracciale a resistenza. Assicurarsi che i componenti e anche gli utensili con quali si lavora siano anche a questo potenziale.

(GB) ESD PROTECTION EQUIPMENT

Complete Kit ESD3 (small tablemat, wristband, connection box, extension cable and earth cable 4822 310 10671
Wristband tester 4822 344 13999

(GB)

Safety regulations require that the set be restored to its original condition and that parts which are identical with those specified, be used.

Safety components are marked by the symbol Δ .

(NL)

Veiligheidsbepalingen vereisen, dat het apparaat bij reparatie in zijn oorspronkelijke toestand wordt teruggebracht en dat onderdelen, identiek aan de gespecificeerde, worden toegepast.

De Veiligheidsonderdelen zijn aangeduid met het symbol Δ .

(F)

Les normes de sécurité exigent que l'appareil soit remis à l'état d'origine et que soient utilisés les pièces de rechange identiques à celles spécifiées.

Les composants de sécurité sont marqués Δ .

(D)

Bei jeder Reparatur sind die geltenden Sicherheitsvorschriften zu beachten. Der Originalzustand des Geräts darf nicht verändert werden; für Reparaturen sind Original-Ersatzteile zu verwenden.

Sicherheitsbauteile sind durch das Symbol Δ markiert.

(I)

Le norme di sicurezza esigono che l'apparecchio venga rimesso nelle condizioni originali e che siano utilizzati i pezzi di ricambio identici a quelli specificati.

Componenti di sicurezza sono marcati con Δ .

(GB)

After servicing and before returning set to customer perform a leakage current measurement test from all exposed metal parts to earth ground to assure no shock hazard exist, The leakage current must not exceed 0.5mA.

**(GB) Warning !**

Invisible laser radiation when open.
Avoid direct exposure to beam.

(S) Varning !

Osynlig laserstrålning när apparaten är öppnad och spärren är urkopplad. Betrakta ej strålen.

(SF) Varoitus !

Avatussa laitteessa ja suojauslaitteiden ohitettaessa olet alttiina näkymättömälle laserisäteilylle. Älä katso säteeseen!

(DK) Advarsel !

Usynlig laserstrålning ved åbning når sikkerhedsafbrydere er ude af funktion. Undgå udsættelse for stråling.

(F)

"Pour votre sécurité, ces documents doivent être utilisés par des spécialistes agréés, seuls habilités à réparer votre appareil en panne".

Pb(Lead) Free Solder

When soldering, be sure to use the pb free solder.

IDENTIFICATION:

Regardless of special logo (not always indicated) 

one must treat all sets from **1 Jan 2005** onwards, according next rules:

Important note: In fact also products of year 2004 must be treated in this way as long as you avoid mixing solder-alloys (lead-free/ lead-free). So best to always use SAC305 and the higher temperatures belong to this.

Due to lead-free technology some rules have to be respected by the workshop during a repair:

- Use only lead-free solder alloy Philips SAC305 with order code 0622 149 00106. If lead-free solder-paste is required, please contact the manufacturer of your solder-equipment. In general use of solder-paste within workshops should be avoided because paste is not easy to store and to handle.
- Use only adequate solder tools applicable for lead-free solder alloy. The solder tool must be able
 - To reach at least a solder-temperature of 400°C,
 - To stabilize the adjusted temperature at the solder-tip
 - To exchange solder-tips for different applications.
- Adjust your solder tool so that a temperature around 360°C – 380°C is reached and stabilized at the solder joint. Heating-time of the solder-joint should not exceed ~ 4 sec. Avoid temperatures above 400°C otherwise wear-out of tips will rise drastically and flux-fluid will be destroyed. To avoid wear-out of tips switch off unused equipment, or reduce heat.
- Mix of lead-free solder alloy / parts with leaded solder alloy / parts is possible but PHILIPS recommends strongly to avoid mixed solder alloy types (leaded and lead-free).

If one cannot avoid or does not know whether product is lead-free, clean carefully the solder-joint from old solder alloy and re-solder with new solder alloy (SAC305).

- Use only original spare-parts listed in the Service-Manuals. Not listed standard-material (commodities) has to be purchased at external companies.
- Special information for BGA-ICs:
 - Always use the 12nc-recognizable soldering temperature profile of the specific BGA (for de-soldering always use the lead-free temperature profile, in case of doubt)
 - Lead free BGA-ICs will be delivered in so-called 'dry-packaging' (sealed pack including a silica gel pack) to protect the IC against moisture. After opening,

dependent of MSL-level seen on indicator-label in the bag, the BGA-IC possibly still has to be baked dry. (MSL=Moisture Sensitivity Level). This will be communicated via AYS-website.

Do not re-use BGAs at all.

- For sets produced before 1.1.2005 (except products of 2004), containing leaded solder-alloy and components, all needed spare-parts will be available till the end of the service-period. For repair of such sets nothing changes.
- On our website www.atyourservice.ce.Philips.com you find more information to:
 - BGA-de-/soldering (+ baking instructions)
 - Heating-profiles of BGAs and other ICs used in Philips-sets

You will find this and more technical information within the "magazine", chapter "workshop news".

For additional questions please contact your local repair-helpdesk.

System , Region Code , etc. Setting Prochure

1)System Reset

- Press "OPTIONS" button on R/C,TV will show setup menu
- Select the menu using the ▼ and ► on R/C
- Go preference page to do system reset

2)Region Code Change

- In open model, press "9" "9" "9" on R/C,then input desired number to change region code :

1	USA
2	EU
3	AP
4	Australia ,NZ , Latam
5	Russia , INDIA
6	CHINA

3)Version Control Change

- In open model, press "1" "5" "9" on R/C
- Press "ok" button to confirm
- TV will show message as below:

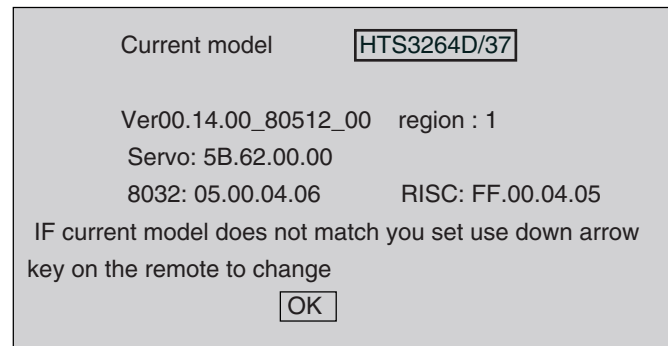

4)Password Change

- Press "OPTIONS" button on R/C,TV will show setup menu
 - Select the menu using the ▼ and ► on R/C
 - Go preference page select "password" to change
- * 000000 is default password supplied.

5)Check on the Sofeware Version

- Open the CD Door
- Press "INFO" button on R/C
- TV will show the version on screen

6)Trade model

- Press "Open/Close" button on R/C
- Press "2" "5" "9" on R/C,VFD will display "TRA ON" or "TRA OFF"

7) Upgrading new software

- Copy "software files" into a CD-R
- Open the CD Door,then insert the CD-R program disc
- Close the CD Door
- VFD will show:

"Loading"
 "Erase" -- erase the flash memory
 "Writing" about 1 minute
 "done "

* the system will switch off and on again automatically.

- OSD will show:

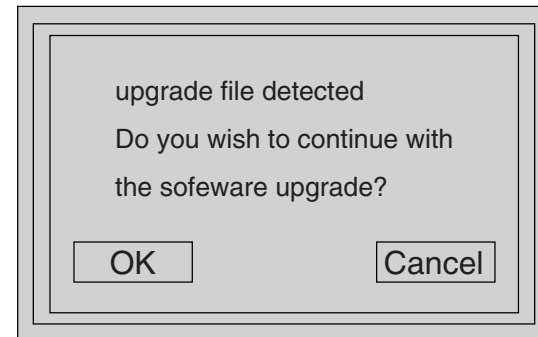

- Select "OK", OSD will show:

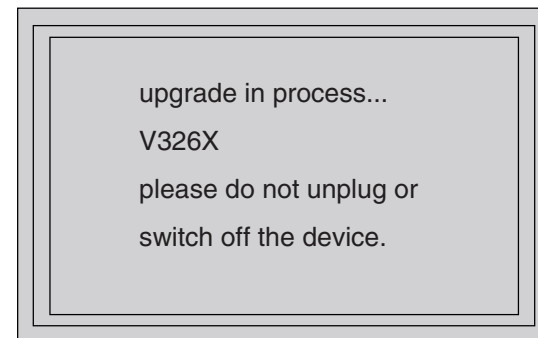

CAUTION!

This information is confidential and may not be distributed.Only a qualified service person should reprogram the Region Code.

REPAIR INSTRUCTIONS (part one)

MAIN UNIT REPAIR CHART

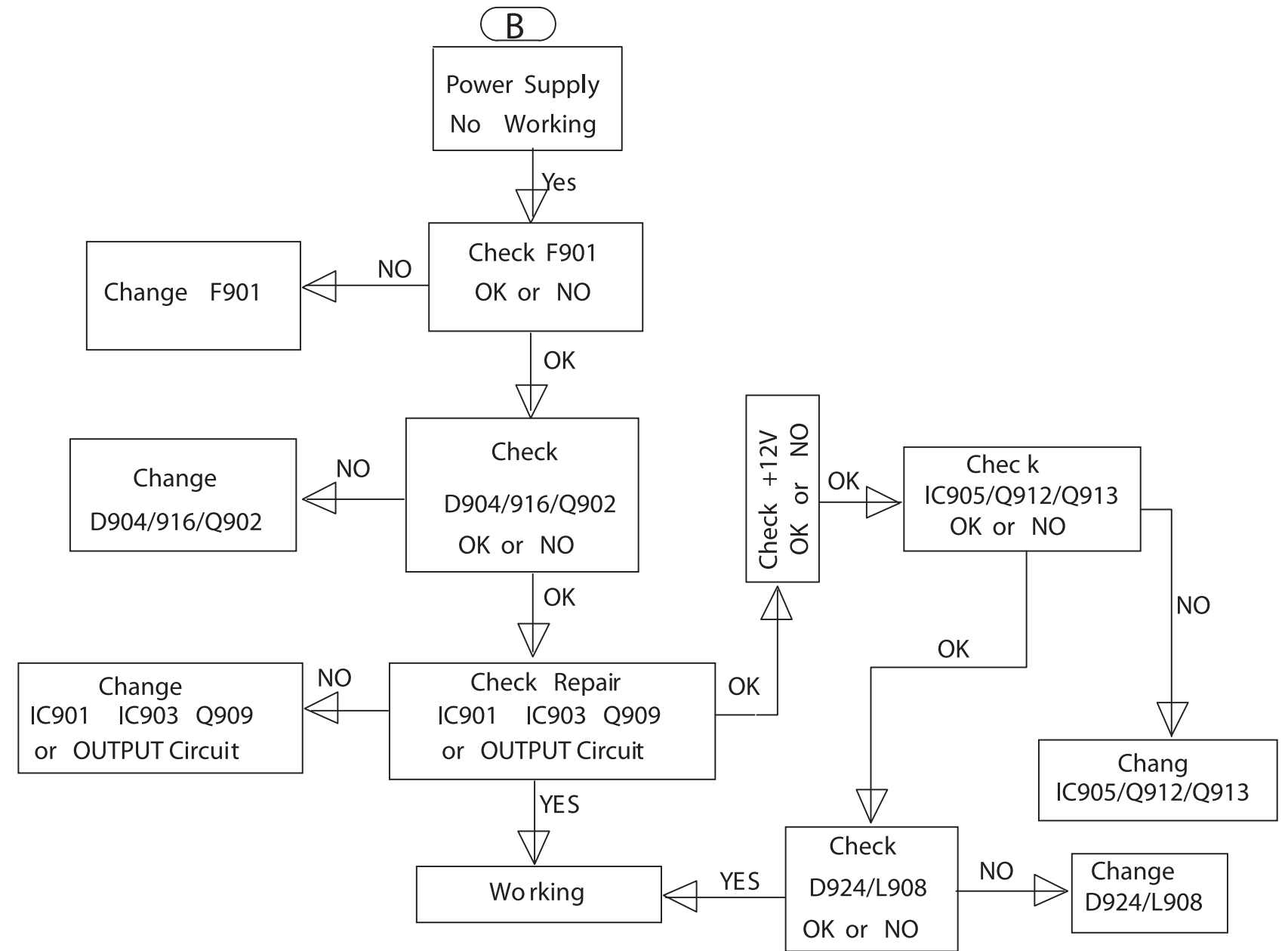
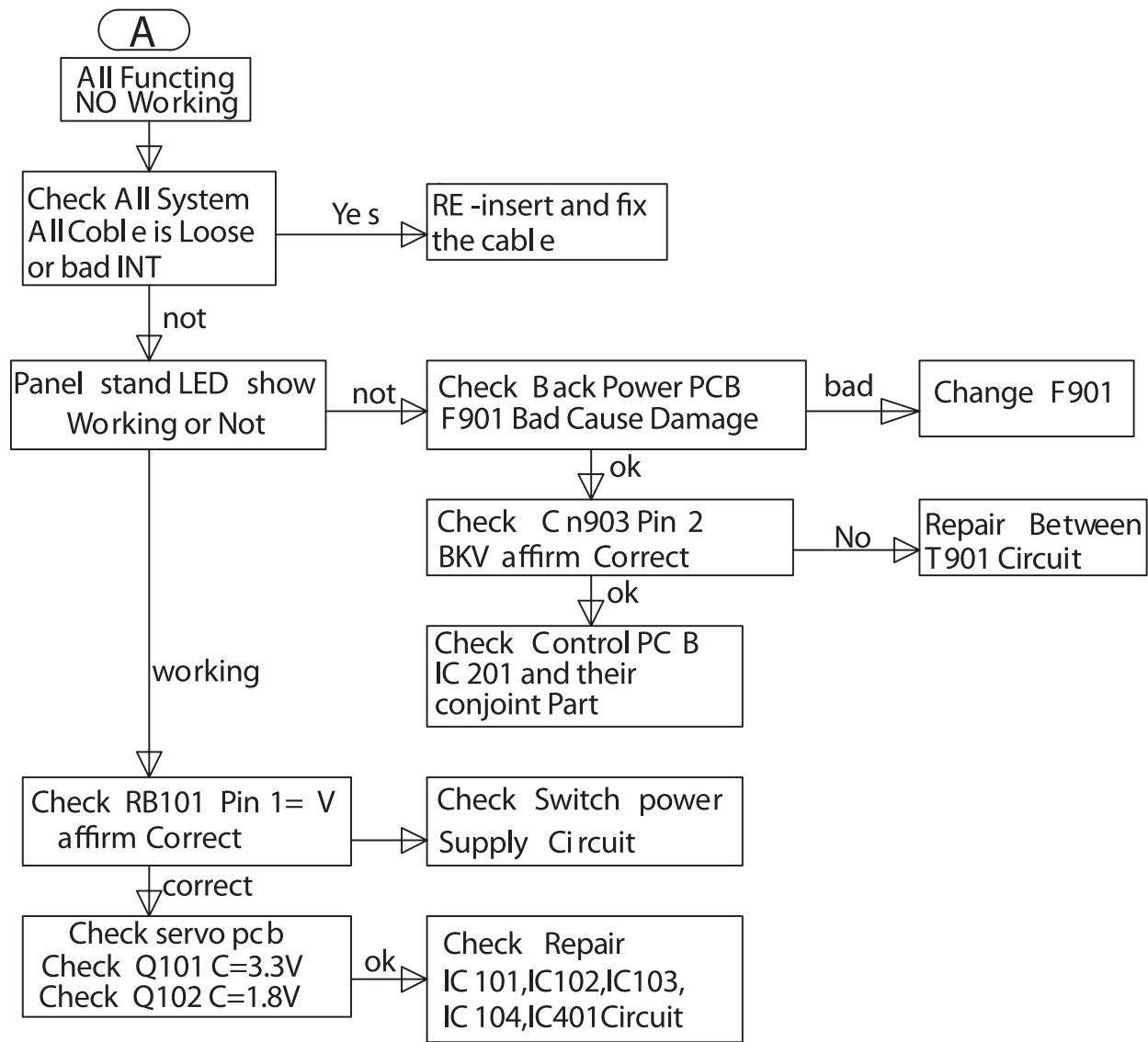
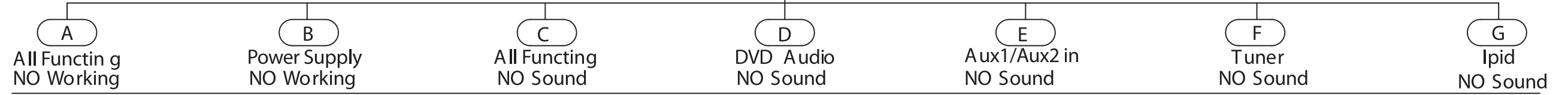

REPAIR INSTRUCTIONS (part two)

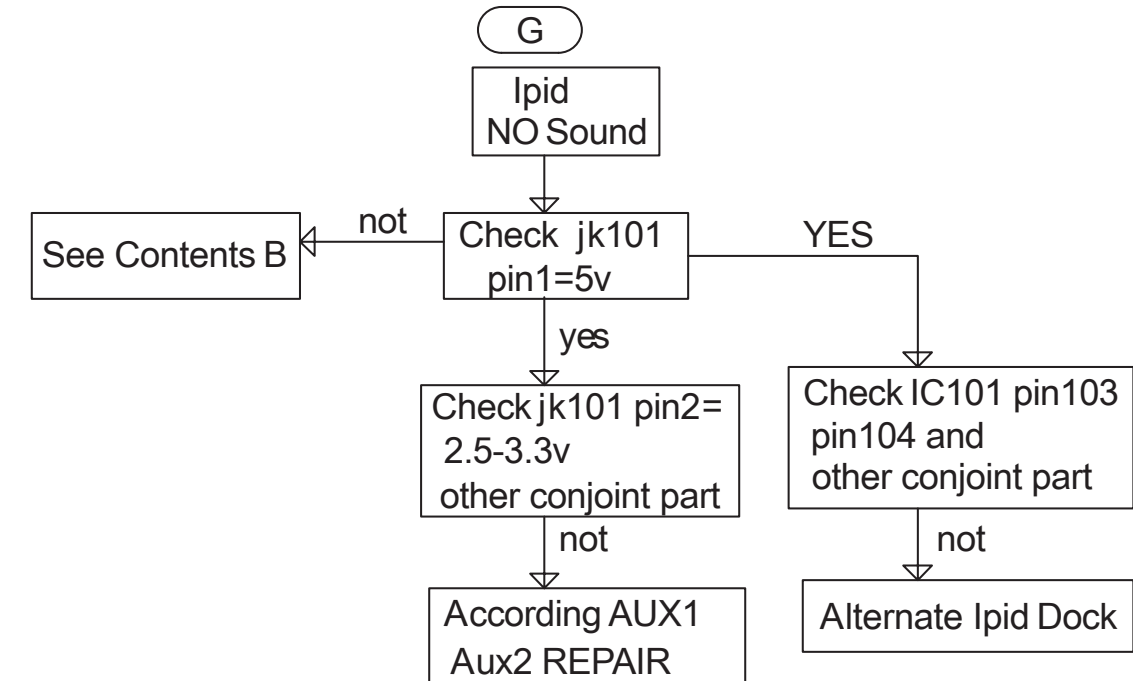
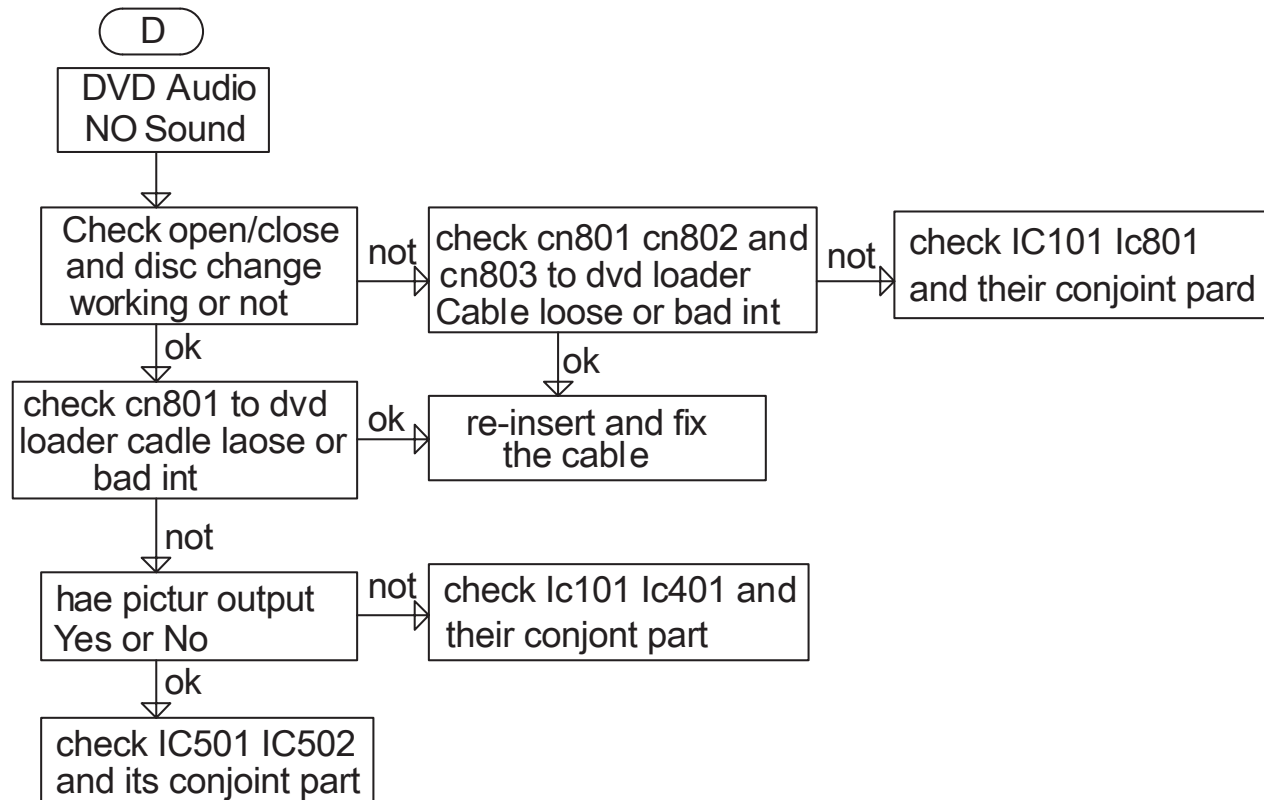
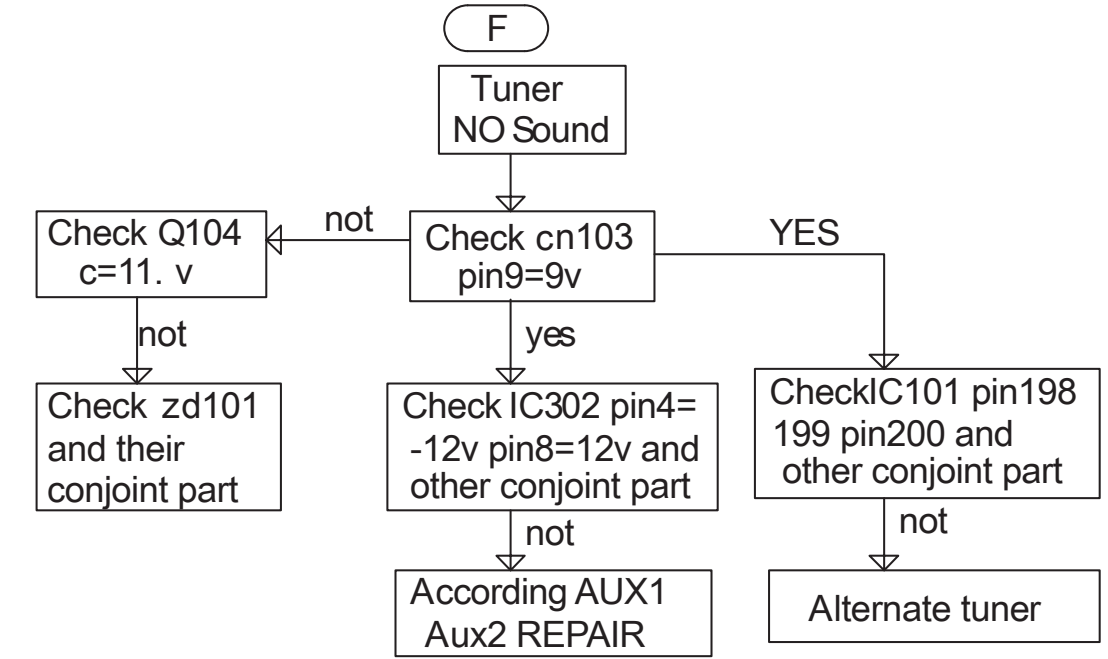
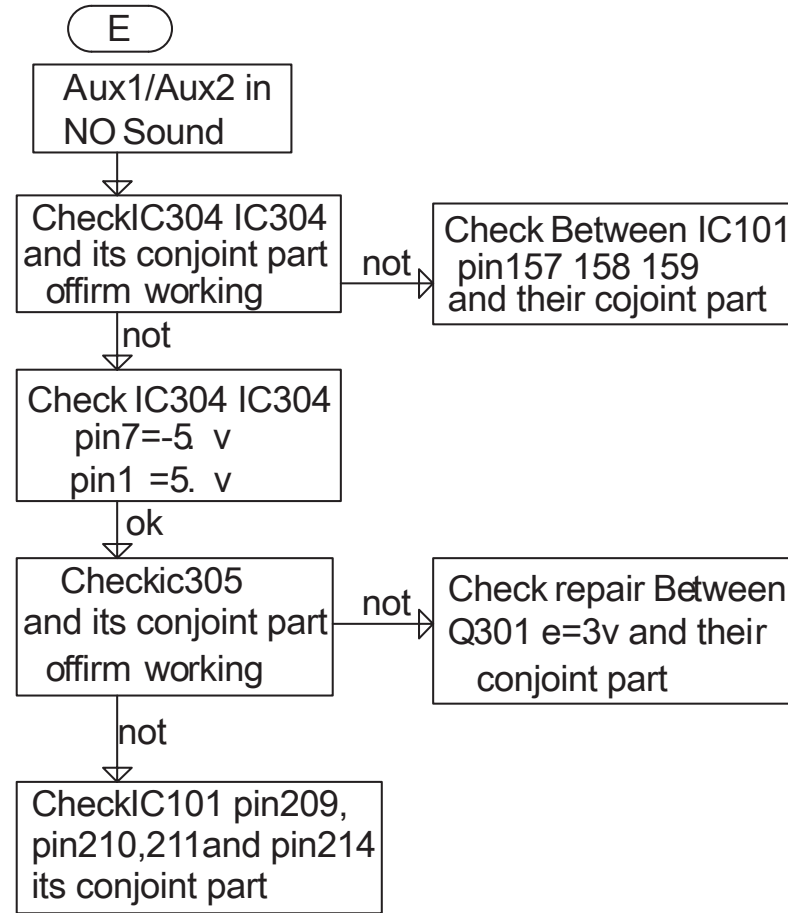
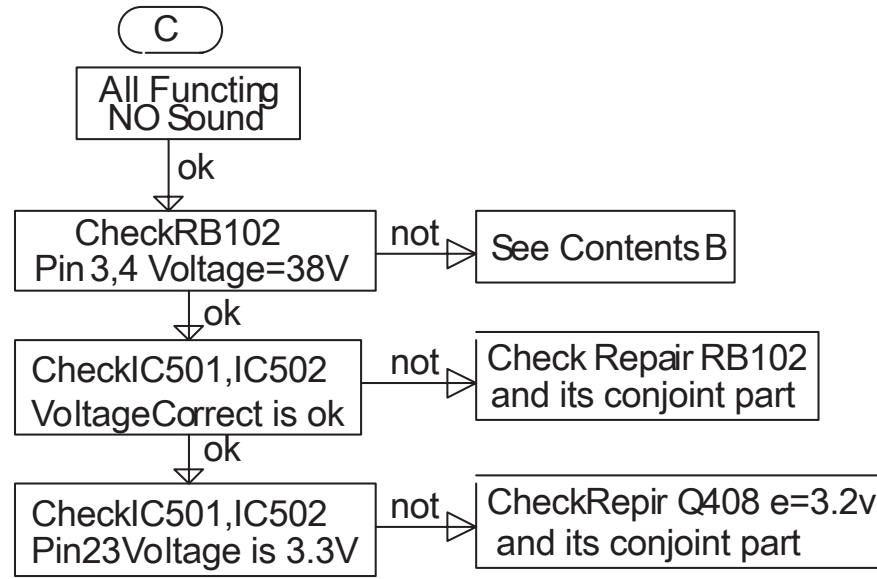

DISASSEMBLY INSTRUCTIONS

Dismantling of the Front Panel Assemble

- 1) Open the DVD Tray by using the Open/Close Button while the Set is ON and disconnect the mains supply after removing the Tray Cover.
Note: If this is not possible, the DVD Tray has to be open manually.
Take a mini screw driver about 2mm diameter and make a marking 24mm from the tip as shown in figure 2 . Place the set on its side, insert the mini screw driver till the marking and slide it towards the left as shown in figure 1 until the Tray moves out of the Front Panel.
- 2) Return the set to its upright position and remove the Tray Cover as shown in Figure 3 and close the tray manually by pushing it back in.

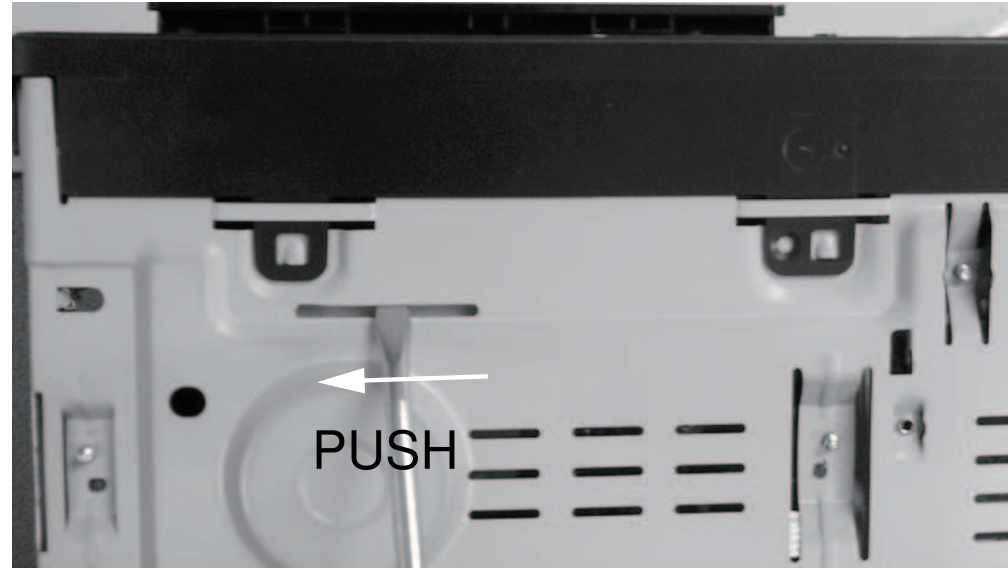

Figure 1



Figure 2

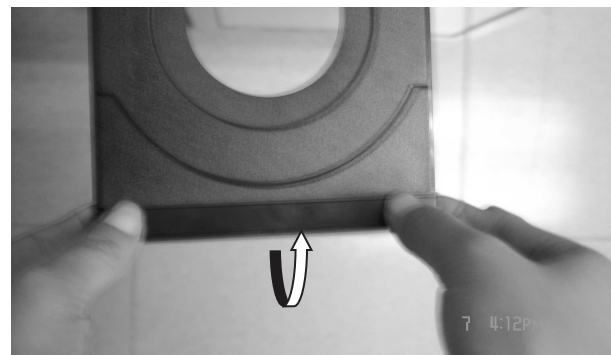

Figure 3

- 3) Loosen 6 screws and remove the Top Cover by lifting the rear portion upwards before sliding it out towards the rear.
 - 1 screw "A" each on the left & right side as shown in figure 4.
 - 4 screws "B" at the back panel as shown in figure 5.
- 4) Loosen 6 screws "C" at the bottom panel as in figure 6 to remove the front panel.

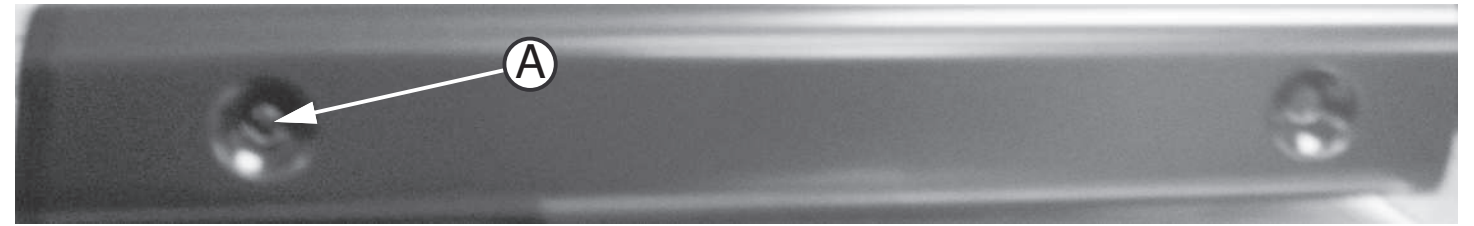

Figure 4

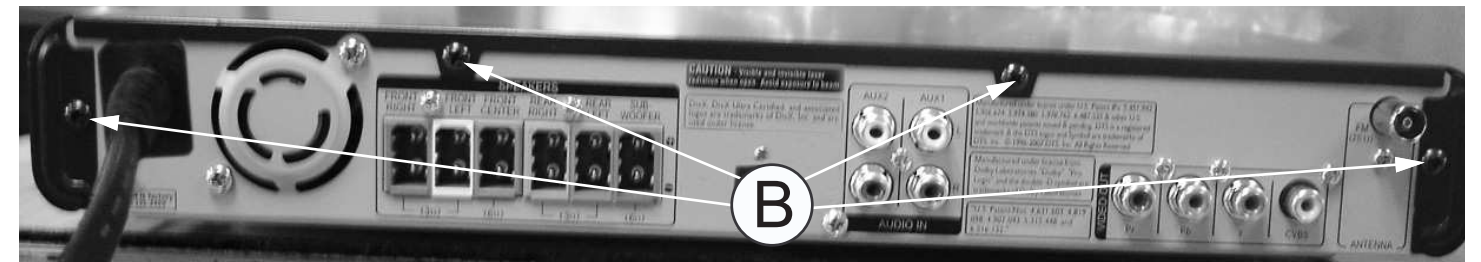

Figure 5

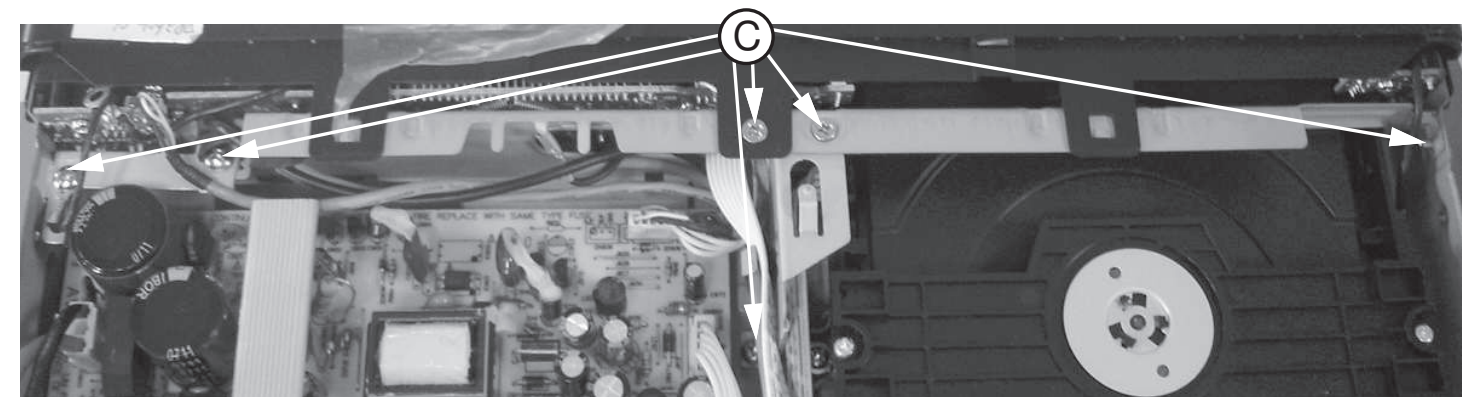

Figure 6

- 1) Loosen 4 screws "D" on the top of power board as shown in figure 7.
- 2) With a pincers to nip this space as shown in figure 8 and to take up the power board.

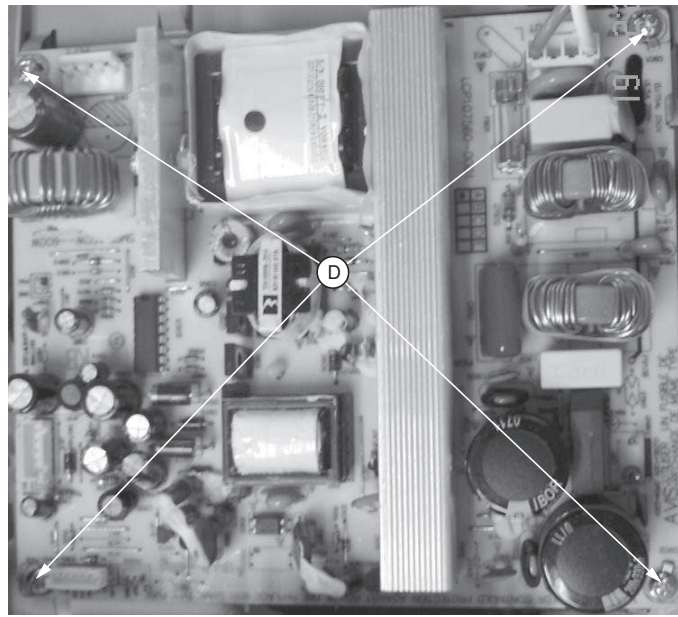

Figure 7

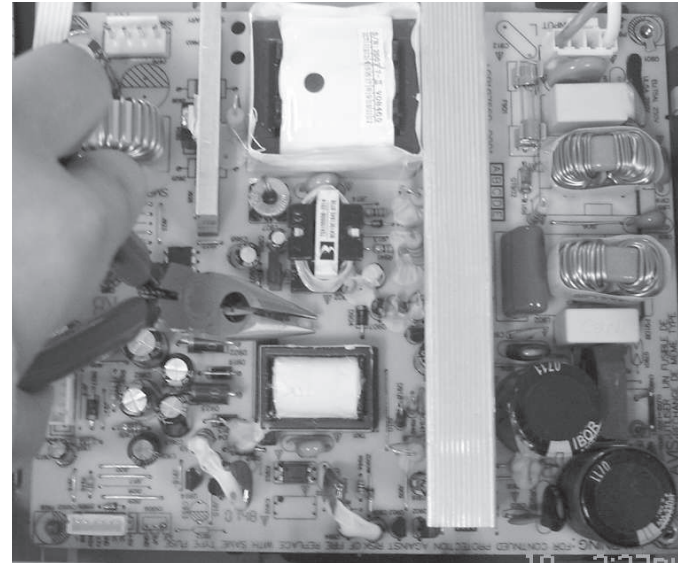

Figure 8

Dismantling of the Main Board

- 1) Loosen 4 screws "E" on the top of main board as shown in figure 9.
- 2) Loosen 6 screws "F" at the back panel as shown in figure 10.

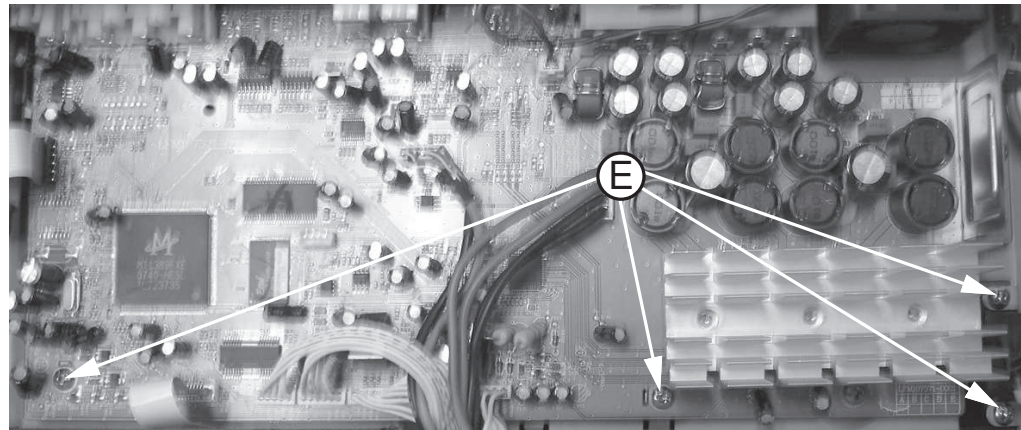

Figure 9

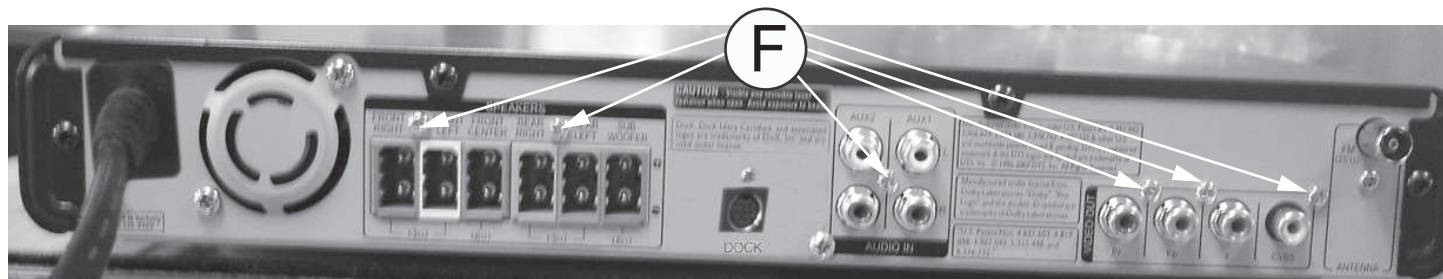

Figure 10

- 1) Loosen 4 screws "G" at the DVD module as shown in figure 11.

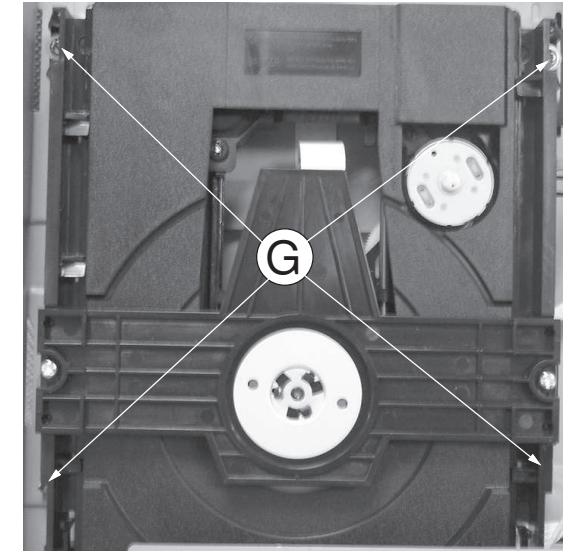

Figure 11

Dismantling of the VFD+JACK+STANDBY Board

- 1) Loosen 10 screws "H" on the top of VFD+JACK+STANDBY board as shown in figure 12.

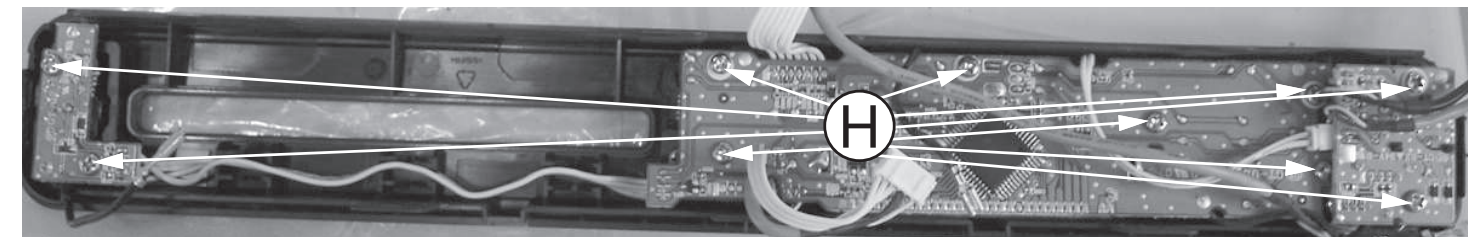

Figure 12

Dismantling of the Ipod Board

- 1) Loosen 1 screw "I" at the back panel as shown in figure 13.

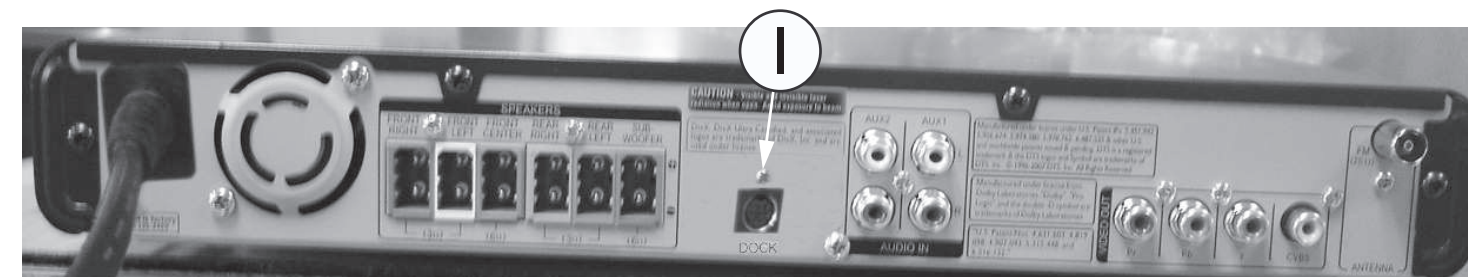

Figure 13

SERVICE POSITIONS

3 - 3

3 - 3

Service position A

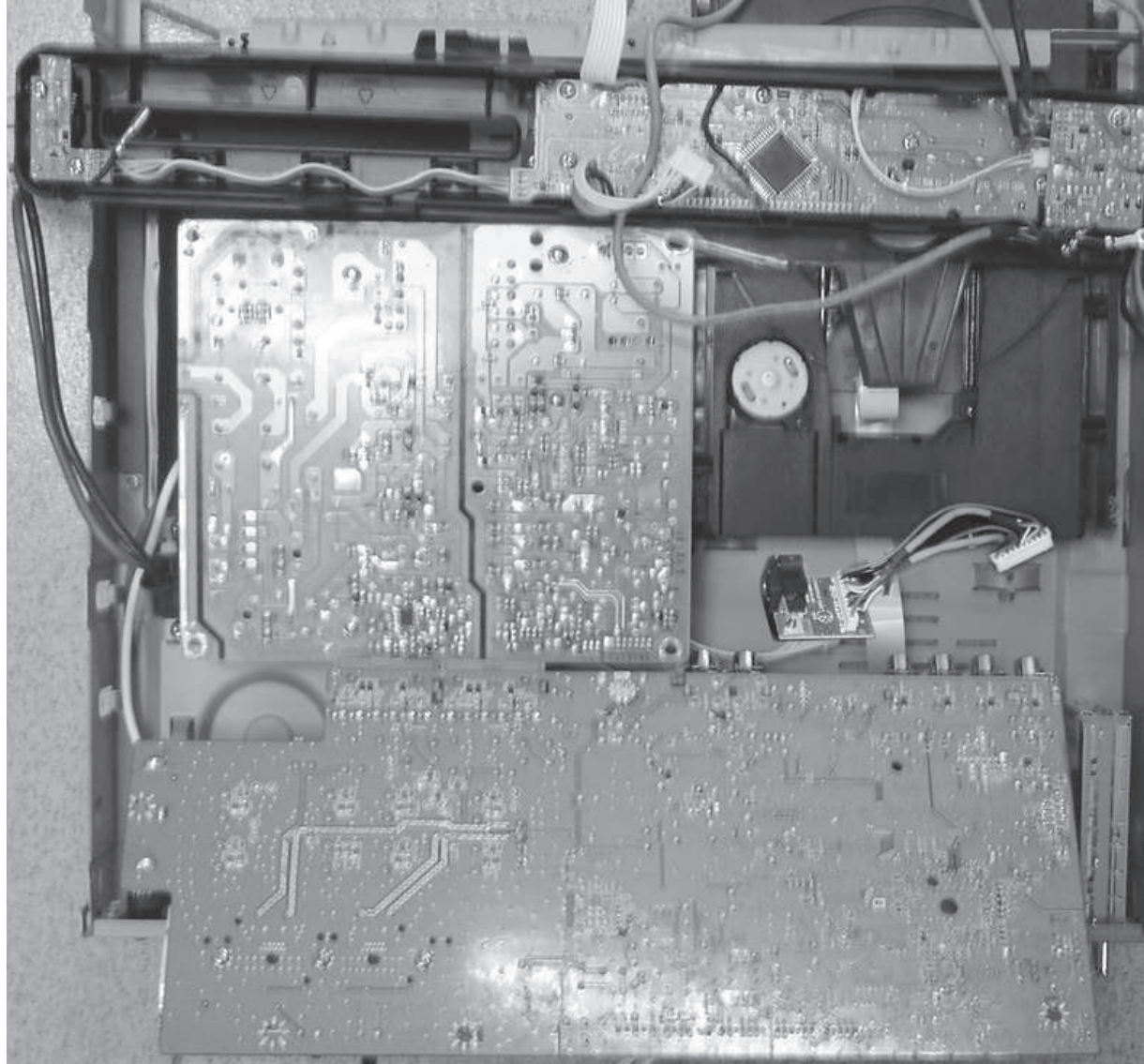

Note: In some service positions the components or copper patterns of one board may risk touching its neighbouring pc boards or metallic parts. To prevent such short-circuit use a piece of hard paper or other insulating material between them.

WIRING DIAGRAM

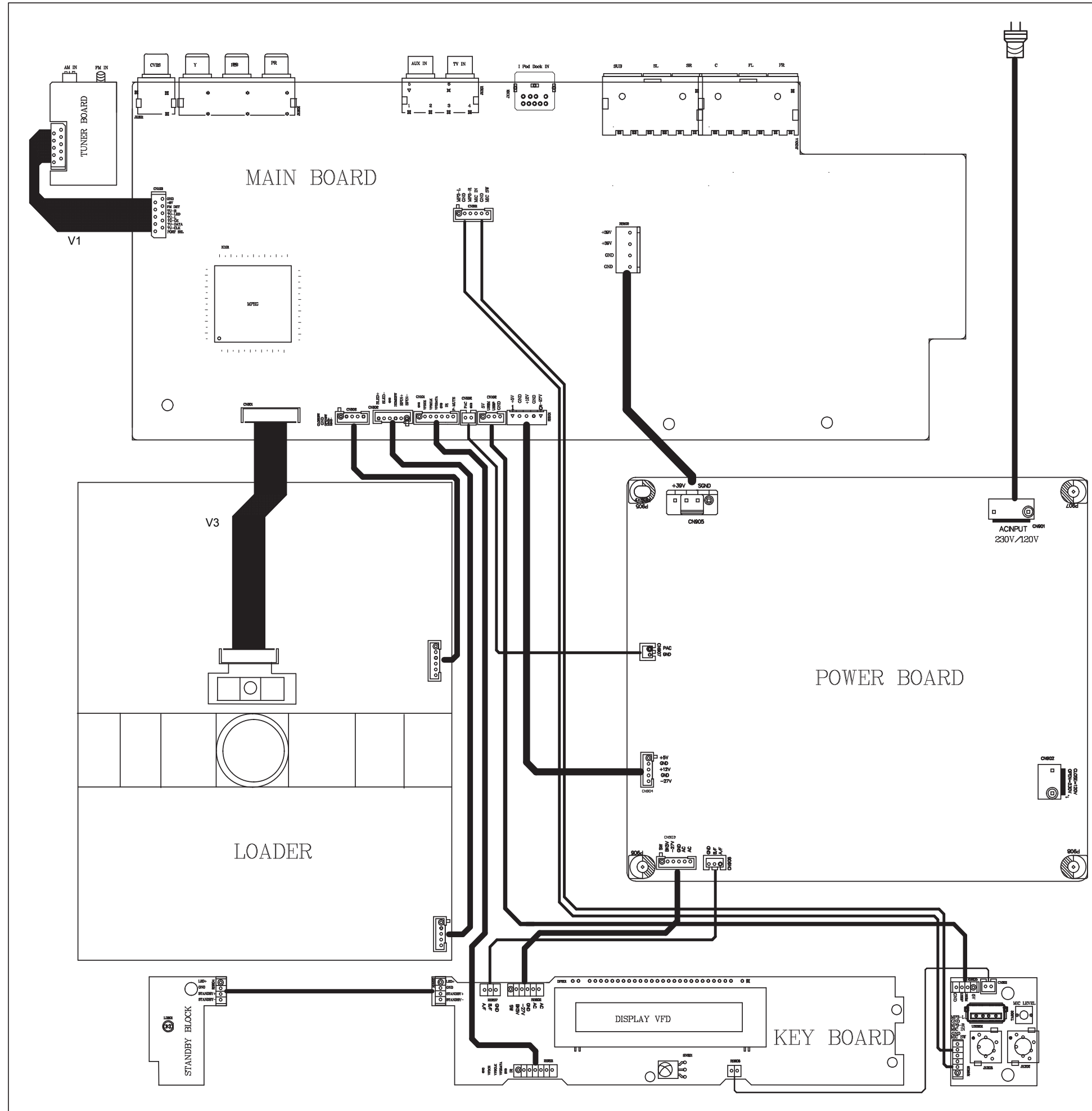

FTD DISPLAY PIN ASSIGNMENT

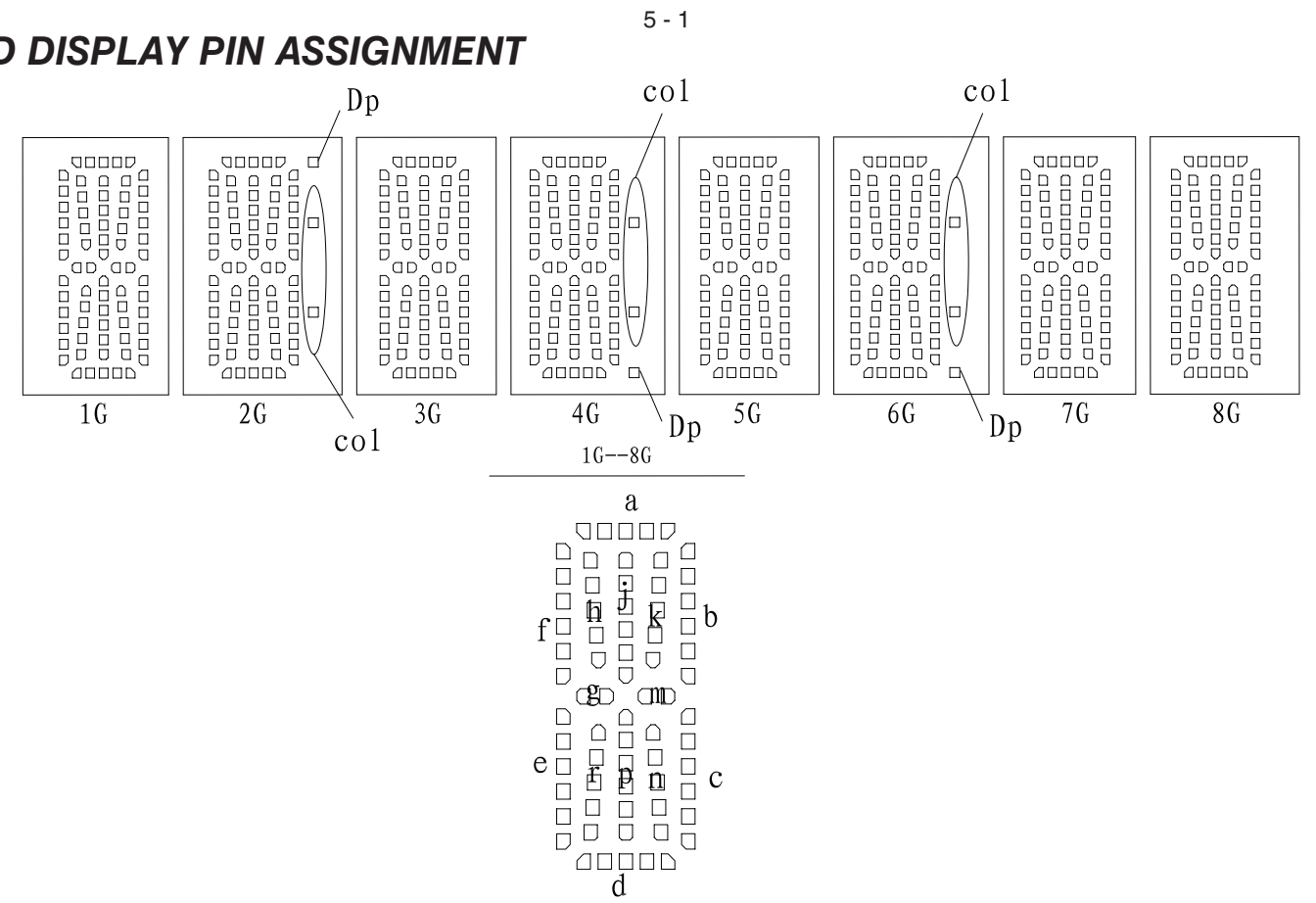

CONTROL BOARD

TABLE OF CONTENTS

FTD Display Pin Assignment.....5-1
 Circuit Diagram5-2
 PCB Layout Top & Bottom View.....5-3

	1G	2G	3G	4G	5G	6G	7G	8G
P1	a	a	a	a	a	a	a	a
P2	j, p	j, p	j, p	j, p	j, p	j, p	j, p	j, p
P3	h	h	h	h	h	h	h	h
P4	k	k	k	k	k	k	k	k
P5	b	b	b	b	b	b	b	b
P6	f	f	f	f	f	f	f	f
P7	m	m	m	m	m	m	m	m
P8	g	g	g	g	g	g	g	g
P9	c	c	c	c	c	c	c	c
P10	e	e	e	e	e	e	e	e
P11	r	r	r	r	r	r	r	r
P12	n	n	n	n	n	n	n	n
P13	d	d	d	d	d	d	d	d
P14	/	col	/	col	/	col	/	/
P15	/	Dp	/	Dp	/	Dp	/	/

PIN CONNECTION

管脚序号 (Pin NO.)	1	2	3	4	5	6	7	8	9	10	11	12	13	14	15	16
连接 (Connection)	F1	F1	NP	NC	P15	P14	NC	P13	P12	P11	P10	P9	P8	P7	P6	P5
管脚序号 (Pin NO.)	17	18	19	20	21	22	23	24	25	26	27	28	29	30	31	32
连接 (Connection)	P4	P3	P2	P1	NC	1G	2G	3G	4G	5G	6G	7G	8G	NP	F2	F2

注 (Notes) : Fn : 灯丝 (Filament Pin) nG : 栅极 (Grid Pin)
 Pn : 阳极 (Anode Pin) NP : 无引出脚 (No Pin)
 NC : 无功能 (No connection Pin)

CIRCUIT DIAGRAM

C201 C2 C205 C1 C209 C1 C213 A1 C229 D4 C233 D1 C237 D1 D202 D1 DP201 A3 FB204 C4 JK203 C4 R203 C1 R207 D2 R211 C1 R215 C1 R219 B2 R225 A2 R232 B4 RB203 A1 TA201 D4 TA206 D1 TA210 D1 ZD202 C1 ZD206 D4
 C202 C2 C206 C1 C210 C1 C214 A2 C230 C1 C234 D1 C238 B4 D204 D2 FB201 C4 FB205 C4 LD201 D4 R204 C1 R208 D2 R212 C1 R216 C1 R222 B1 R226 A2 R233 C4 RB205 C4 TA203 D1 TA207 D1 USB201 C4 ZD203 C1 ZD207 D4
 C203 C2 C207 C1 C211 C1 C215 A2 C231 C1 C235 D1 C239 B4 D205 D2 FB202 C4 FB206 B4 Q201 C1 R205 C1 R209 D1 R213 C1 R217 B2 R223 B2 R227 D4 RB201 B1 RB206A B4 TA204 D1 TA208 D1 XL201 C2 ZD204 A2
 C204 C1 C208 C1 C212 C1 C228 D4 C232 C2 C236 D1 D201 D1 D206 D2 FB203 C4 IC201 C2 R202 C1 R206 D2 R210 C1 R214 B1 R218 B2 R224 A2 R231 D4 RB202 A1 SN201 C1 TA205 D1 TA209 D1 ZD201 C1 ZD205 A2

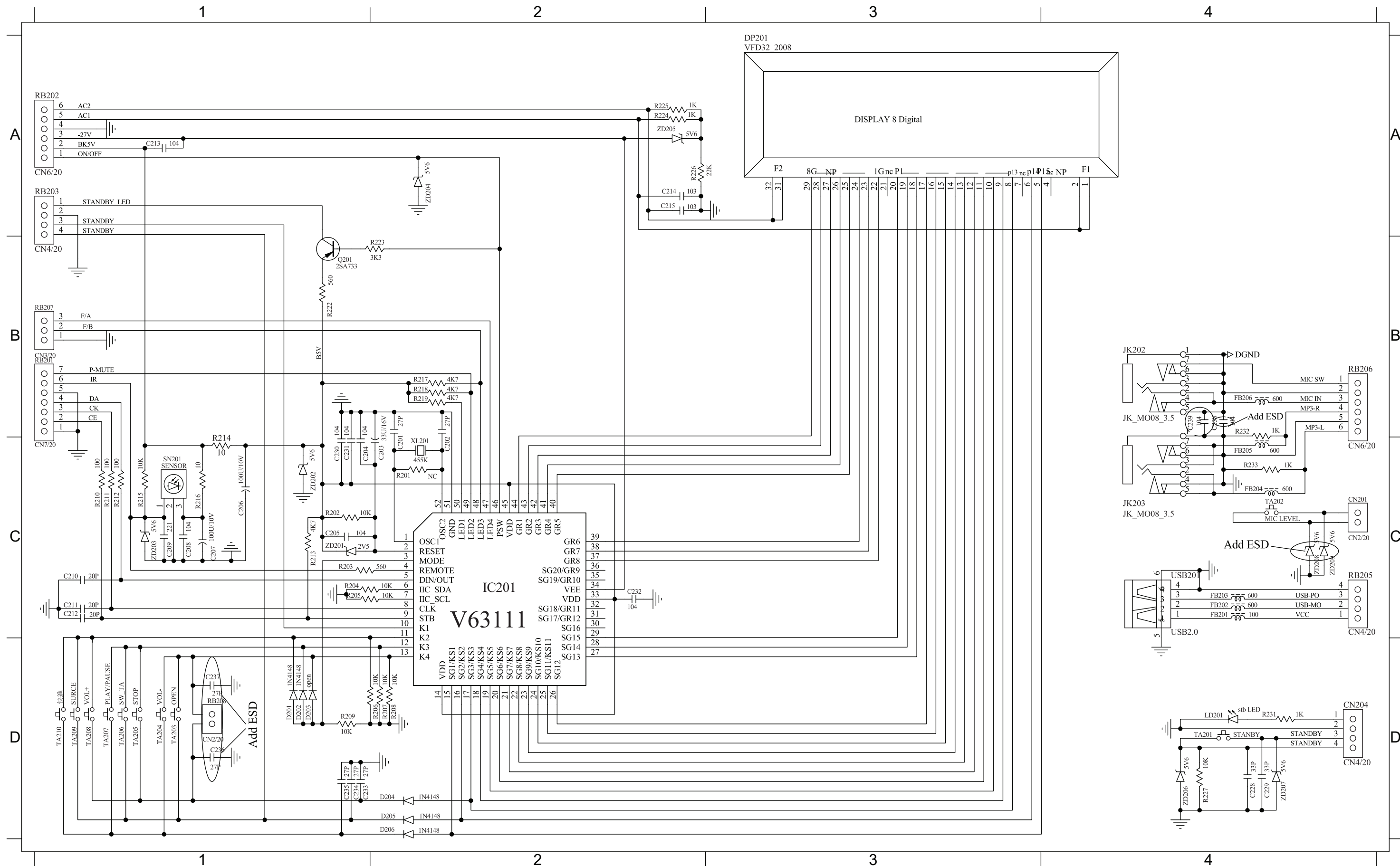

PCB LAYOUT - TOP VIEW

C203 A2 C207 A2 ESD1 A2 ESD6 A1 JK203 A5 RB201 A2 RB203 A1 RB206AA5 TA201 A1 TA204 A3 TA206 A4 TA208 A3 TA210 A5 XL201 A3
 C206 A2 DP201 A2 ESD2 A4 ESD7 A5 LD201 A1 RB202 A2 RB205 A5 SN201 A3 TA203 A1 TA205 A4 TA207 A4 TA209 A4 USB201A5

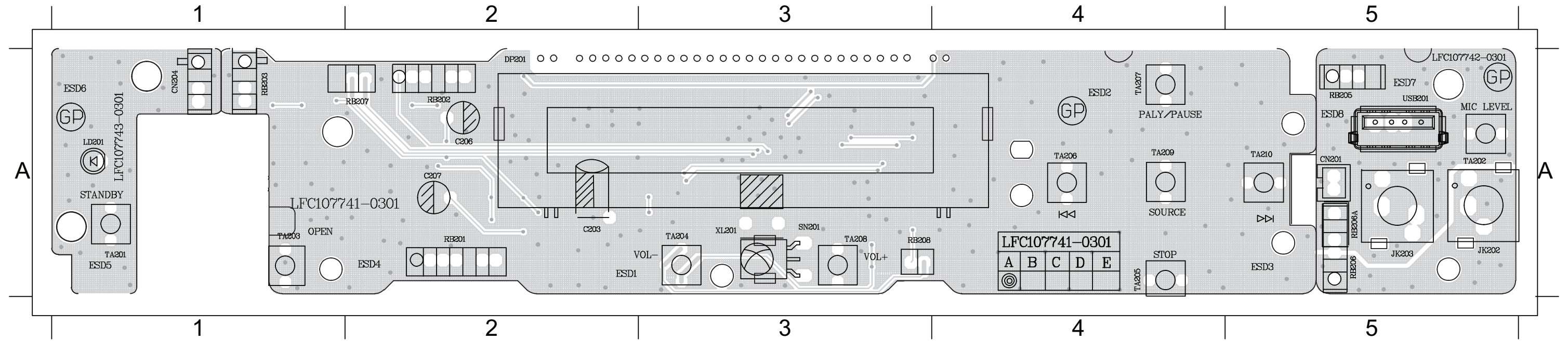

PCB LAYOUT - BOTTOM VIEW

C201 A3 C208 A3 C212 A4 C228 A5 C232 A3 C236 A3 D201 A4 D206 A3 FB204 A1 Q201 A5 R205 A3 R209 A3 R213 A4 R217 A3 R223 A5 R227 A5 ZD201 A4 ZD205 A4
 C202 A3 C209 A3 C213 A4 C229 A5 C233 A3 C237 A3 D202 A4 FB201 A1 FB205 A1 R202 A4 R206 A4 R210 A4 R214 A4 R218 A3 R224 A4 R231 A5 ZD202 A4 ZD206 A5
 C204 A3 C210 A4 C214 A4 C230 A3 C234 A4 C238 A1 D204 A3 FB202 A1 FB206 A1 R203 A4 R207 A3 R211 A4 R215 A4 R219 A3 R225 A4 R232 A1 ZD203 A4 ZD207 A5
 C205 A4 C211 A4 C215 A2 C231 A3 C235 A3 C239 A1 D205 A4 FB203 A1 IC201 A3 R204 A3 R208 A4 R212 A4 R216 A4 R222 A5 R226 A4 R233 A1 ZD204 A4

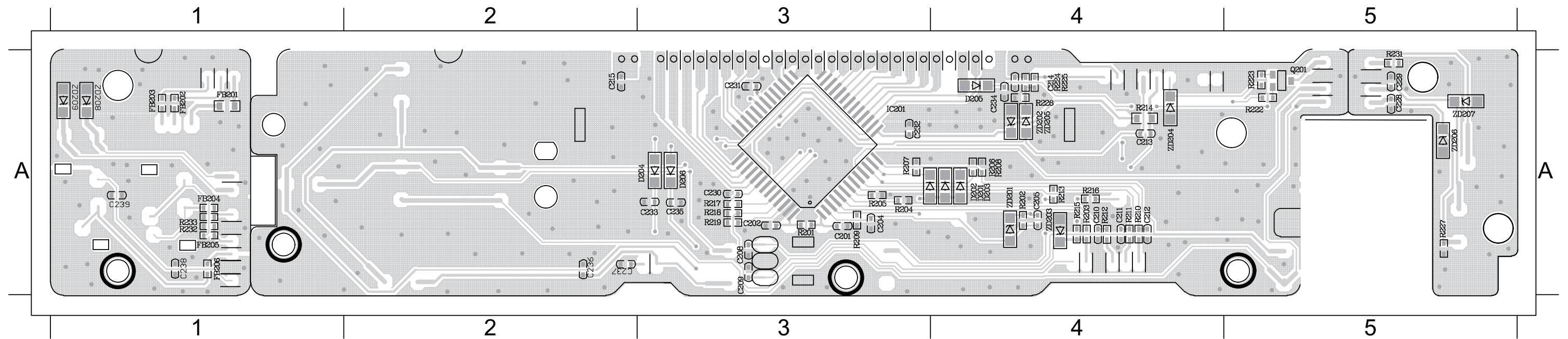

MAIN BOARD

TABLE OF CONTENTS

Internal IC Diagram6-1
 Circuit Diagram (part one)6-2
 Circuit Diagram (part two)6-3
 PCB Layout Top View6-4
 PCB Layout Bottom View6-5

INTERNAL IC DIAGRAM - STA309A

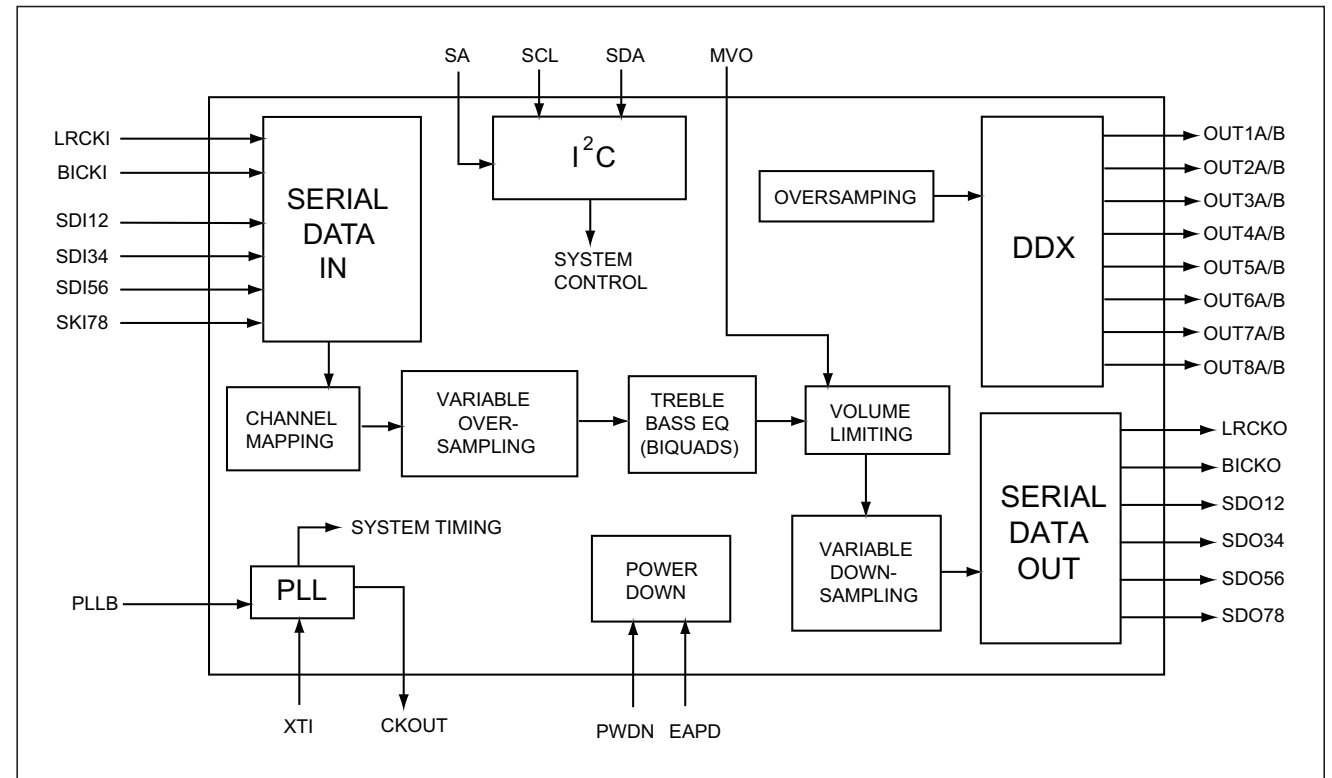

INTERNAL IC DIAGRAM - MT1389HD

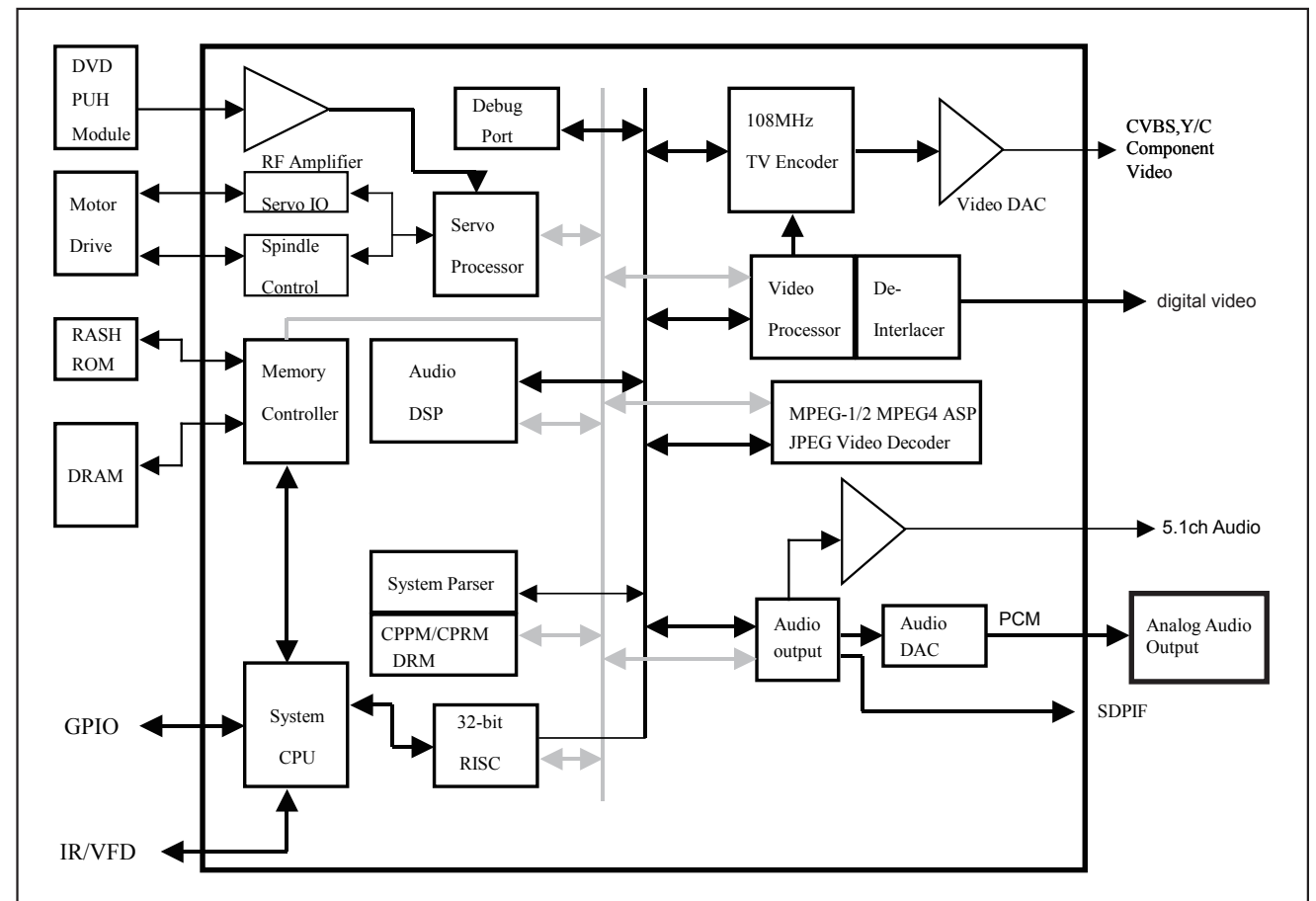

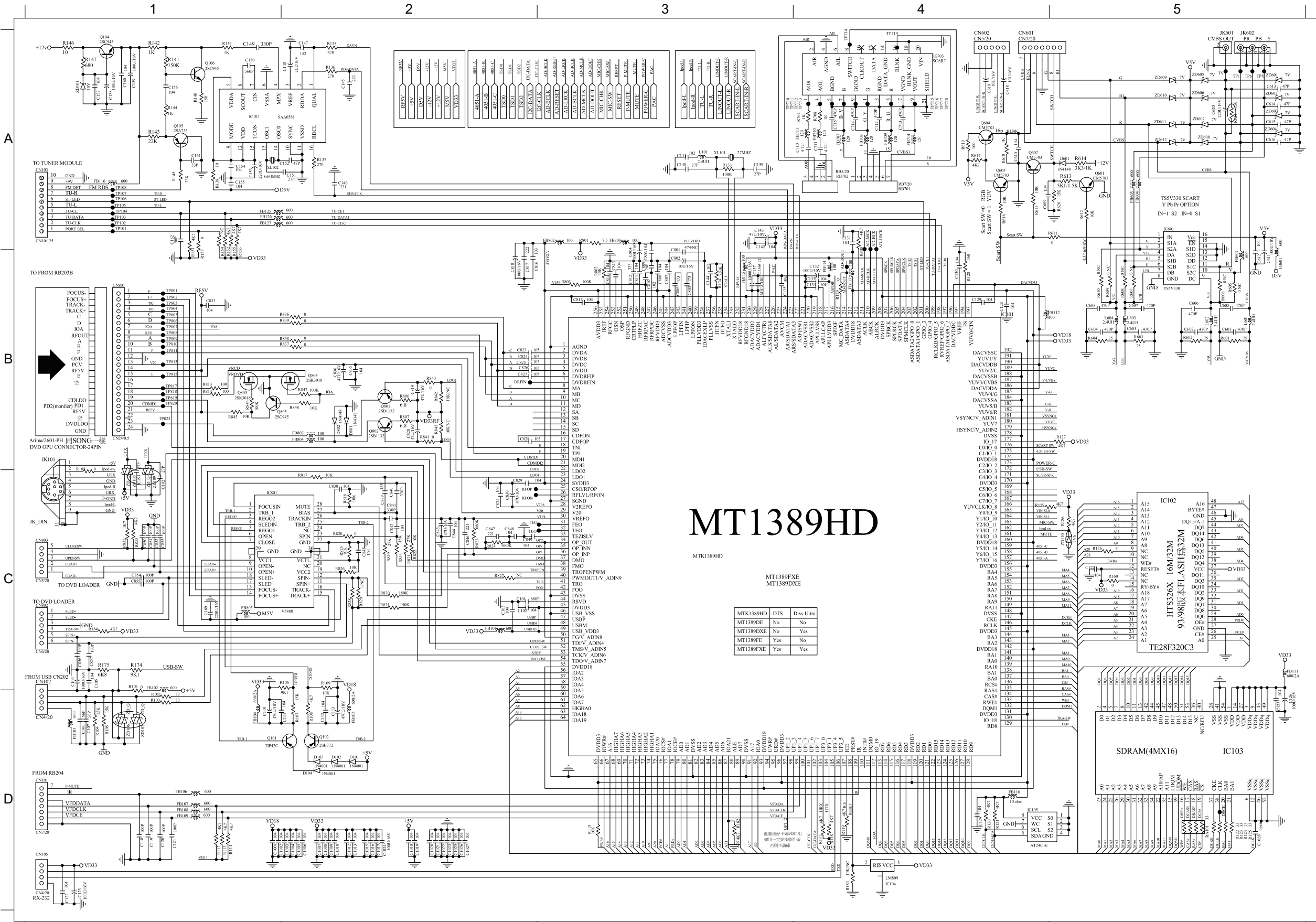

MT1389HD

MTK1389HD DTS Divs Ultra

MT1389DE	No	No
MT1389DXE	No	Yes
MT1389FXE	Yes	No
MT1389FXE	Yes	Yes

- C1001 D1 C608 B5 FB105 D2 R153 A1
- C1002 D1 C609 B5 FB106 D1 R155 A1
- C1003 D2 C611 B5 FB107 D1 R156 A1
- C1004 D2 C612 B5 FB108 D1 R159 C4
- C1005 D2 C613 A5 FB109 D1 R160 C5
- C1006 D2 C614 A5 FB110 D4 R174 C1
- C1007 D2 C615 A5 FB111 C5 R175 C1
- C1008 D2 C616 A5 FB112 B4 R182 D3
- C1009 D2 C620 A5 FB113 B4 R184 C1
- C101 C2 C802 B3 FB114 B4 R185 C1
- C1010 D2 C803 B3 FB115 B3 R186 C5
- C1012 D2 C804 A3 FB116 A1 R601 B5
- C1013 D2 C805 B3 FB125 B1 R602 B5
- C1015 D2 C806 B3 FB126 B1 R603 B5
- C1016 D2 C807 B3 FB127 B1 R604 B5
- C1017 D2 C808 B3 FB201 B5 R605 B5
- C1018 D2 C809 B3 FB602 B5 R607 B5
- C1019 D2 C810 B3 FB603 A5 R610 B5
- C102 C2 C811 B3 FB604 A5 R620 A5
- C1020 D2 C812 B3 FB801 A3 R621 A5
- C1021 D2 C813 B3 FB802 A3 R801 A3
- C1022 D2 C814 B3 FB803 B2 R802 B3
- C1023 D2 C815 B3 FB804 B2 R803 B3
- C1024 D2 C816 B2 FB805 C1 R806 B2
- C1025 D2 C817 B2 IC101 B4 R807 B2
- C1026 D2 C818 B2 IC102 C5 R808 A4
- C1027 D2 C819 B2 IC103 D5 R813 B1
- C1028 D5 C820 B2 IC104 D4 R814 B1
- C103 C2 C823 B2 IC105 D4 R817 C2
- C104 C1 C824 B2 IC801 C1 R818 C2
- C105 C1 C825 B2 JK101 B1 R819 C2
- C106 D1 C826 B2 JK601 A5 R820 C2
- C107 D1 C827 B2 JK602 A5 R821 C2
- C110 D2 C828 B2 L601 B5 R822 C2
- C111 D2 C829 C2 L602 B5 R823 C2
- C112 D2 C830 C2 L603 B5 R824 C2
- C113 D2 C831 C2 L604 B5 R825 C2
- C118 D1 C833 B1 Q101 D1 R826 C2
- C119 D1 C835 B2 Q102 D2 R828 C2
- C120 D1 C836 B2 Q104 A1 R830 C2
- C121 D1 C838 C2 Q801 B2 R831 C2
- C122 D1 C839 C2 Q802 B2 R832 C1
- C123 D1 C840 C2 Q803 B1 R833 C1
- C124 D4 C841 C2 Q804 B2 R836 B1
- C125 D5 C842 C2 Q805 B1 R837 B1
- C126 D5 C843 C2 R101 C1 R838 B1
- C127 C5 C844 C2 R102 C1 R839 B1
- C128 B4 C845 C2 R103 C1 R840 B2
- C129 B4 C846 C2 R104 D1 R841 B2
- C130 B4 C847 C2 R105 D1 R844 C2
- C131 A4 C848 C2 R106 C1 R845 B1
- C132 B4 C849 C2 R107 D2 R846 B1
- C133 B4 C850 C1 R108 D2 R847 B2
- C134 B4 C851 C1 R109 C2 R848 B2
- C135 B3 C852 C1 R112 D1 RA101 D5
- C136 B3 C853 C1 R113 D1 XL101 A3
- C137 B3 C854 C1 R114 D1 ZD101 A1
- C139 A3 C855 C1 R115 D3 ZD106 D1
- C140 A3 C856 C1 R117 D4 ZD107 D1
- C142 A3 C857 C1 R118 D4 ZD108 C1
- C143 A3 CN101 D1 R119 D4 ZD109 C1
- C144 B3 CN102 C1 R120 D4 ZD110 B5
- C157 A1 CN103 A1 R121 D4 ZD601 A5
- C158 A1 CN105 D1 R122 D5 ZD602 A5
- C159 A1 CN801 B1 R123 D5 ZD603 A5
- C160 A1 CN802 C1 R124 D5 ZD604 A5
- C162 A1 CN803 C1 R125 D5 ZD605 A5
- C189 C1 D101 D2 R126 C5 ZD606 A5
- C191 C1 D102 D2 R127 B5 ZD607 A5
- C192 C1 D103 D2 R128 B4 ZD608 A5
- C601 B5 D104 D2 R129 B4
- C602 B5 D801 B2 R133 A3
- C603 B5 D802 B2 R134 B3
- C604 B5 FB101 C2 R146 A1
- C605 B5 FB102 C1 R147 A1
- C606 B5 FB103 C1 R151 A1
- C607 B5 FB104 D1 R152 A1

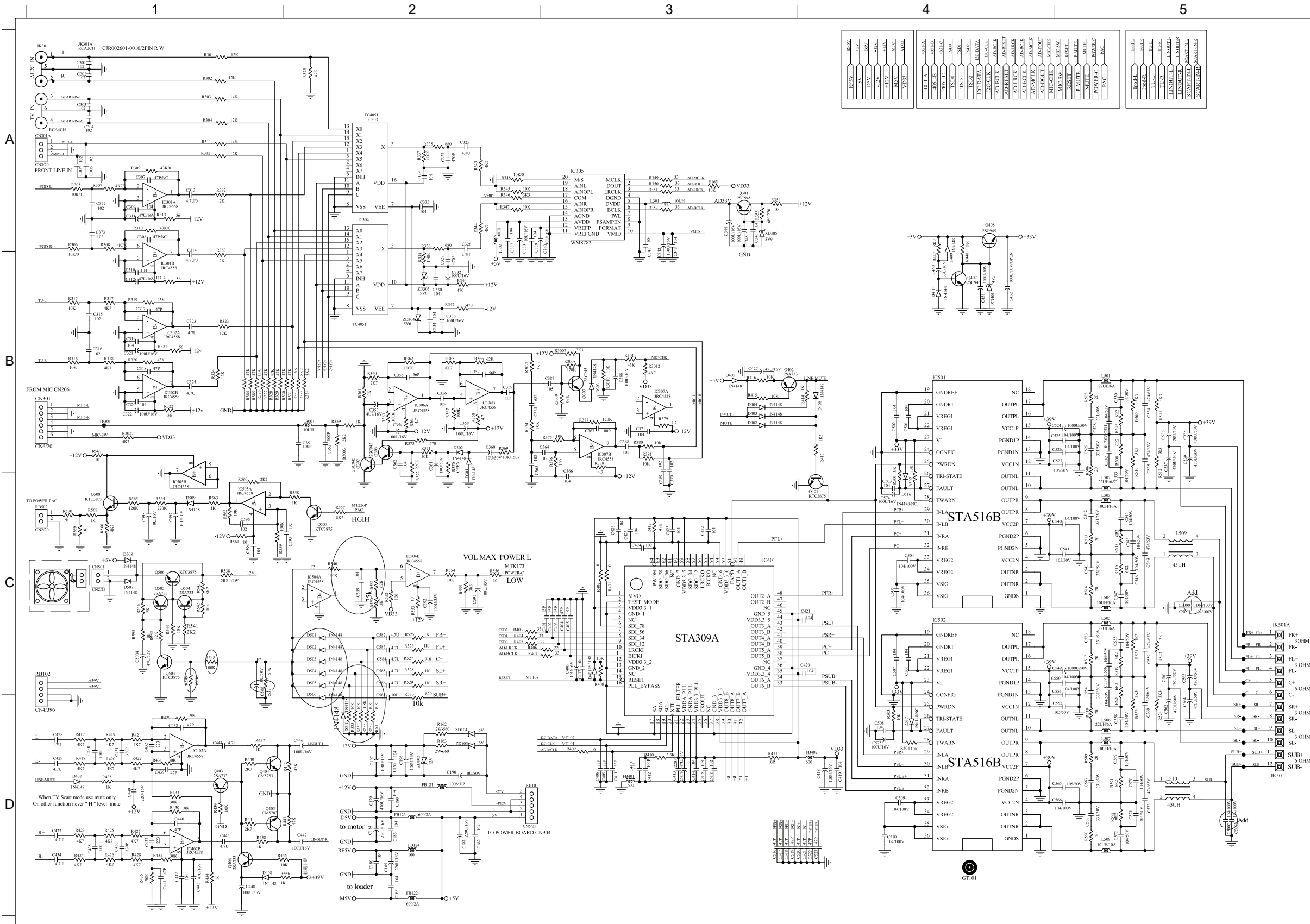

C179	D2	C425	C3	C582	C2	R3012	B3	R505	B5
C180	D2	C426	C3	C583	C2	R302	A1	R506	B5
C181	D2	C427	B3	C584	C2	R3027	B1	R507	B5
C182	D2	C450	B4	C585	C2	R303	A1	R508	B5
C183	D2	C451	B4	C586	C2	R304	A1	R509	B5
C184	D2	C5000	C5	C587	D2	R305	A1	R510	B5
C185	D2	C5001	C5	C588	C1	R306	A1	R511	B5
C186	D2	C5002	D5	C589	C2	R307	A1	R512	B5
C188	D2	C5003	D5	C592	C2	R308	A1	R513	C5
C190	D2	C5004	C1	C593	C2	R309	A1	R514	C5
C195	D2	C501	B4	C594	C1	R310	A1	R515	C5
C196	D2	C502	B4	C595	C2	R311	A1	R516	C5
C197	D2	C503	C4	C596	C1	R312	A1	R517	C5
C301	A1	C504	C4	C597	C1	R313	A1	R518	D5
C302	A1	C505	C4	C598	C1	R314	B1	R519	C5
C303	A1	C506	C4	CN301AB1		R315	B1	R520	D5
C304	A1	C507	C4	CN501	C1	R316	B1	R521	D5
C305	A1	C508	D4	D401	C3	R317	B1	R522	D5
C306	A1	C509	D4	D402	B3	R318	B1	R523	D5
C311	A1	C510	D4	D403	B3	R319	B1	R524	D5
C312	B1	C516	D3	D404	B3	R320	B1	R525	C2
C313	A1	C517	D3	D405	B3	R321	B1	R526	C2
C314	B1	C518	D3	D406	B4	R322	B1	R527	C2
C315	B1	C519	D3	D409	B4	R323	B1	R528	C2
C316	B1	C520	D4	D410	B4	R324	B1	R529	C2
C317	B1	C521	D4	D501	C2	R325	A2	R530	D2
C318	B1	C522	D4	D502	C2	R326	B1	R531	D2
C319	B1	C523	D4	D503	C2	R327	B1	R532	D2
C320	B1	C524	B3	D504	C2	R328	B1	R533	D2
C321	B1	C525	B3	D505	C2	R329	B1	R534	D2
C322	B1	C526	B3	D506	C2	R330	B1	R535	D2
C323	B1	C527	B3	D507	C1	R331	B2	R537	C1
C324	B1	C528	B5	D508	C1	R332	B2	R538	C1
C325	A2	C529	B5	D509	C1	R333	B2	R540	C2
C326	A2	C530	B5	D510	D2	R334	B2	R541	C1
C327	A2	C531	B5	FB121	D2	R335	A2	R542	C1
C328	B2	C532	B5	FB122	D2	R336	A2	R543	C1
C329	A2	C533	B5	FB123	D2	R337	A2	R544	C1
C330	B2	C534	B5	FB124	D2	R338	B2	R545	C1
C332	B2	C535	B5	FB401	D3	R340	B2	R546	C1
C334	B2	C536	B5	FB402	D4	R342	B2	R548	C1
C335	A2	C537	B5	IC302	B1	R343	A2	R549	C1
C336	B2	C538	B5	IC303	A2	R344	A2	R550	C2
C337	A2	C539	B5	IC304	A2	R345	A2	R551	C2
C338	A2	C540	C3	IC305	A3	R346	A2	R552	C2
C339	A2	C541	C4	IC401	C3	R347	A2	R553	C2
C340	A3	C542	C4	IC501	B4	R348	A2	R554	C2
C341	A3	C543	C4	IC502	C4	R349	A3	R555	C2
C342	A3	C544	C4	IC504	C2	R350	A3	R556	C2
C343	A3	C545	C4	IC505	C1	R351	A3	R557	C2
C344	A3	C546	C4	JK301	A1	R352	A3	R558	C2
C345	A3	C547	C4	JK501	C5	R353	A3	R560	C1
C346	A3	C548	C4	JK501AC5		R354	A3	R561	C1
C362	B2	C549	C4	L301	A3	R382	A1	R562	C1
C372	A1	C550	C4	L302	A2	R383	A1	R563	C1
C373	A1	C551	C4	L501	B5	R384	B1	R564	C1
C401	C3	C552	D4	L502	C5	R385	B1	R565	C1
C402	C3	C553	C5	L503	C5	R401	C3	R566	C1
C403	C3	C554	C5	L504	C5	R402	C3	R567	B1
C404	C3	C555	C5	L505	C5	R403	C2	R568	C1
C405	C3	C556	C5	L506	D5	R404	C2	R569	C1
C406	C3	C557	C5	L507	D5	R405	C2	R570	C1
C407	C3	C558	D5	L508	D5	R406	C2	R589	D5
C408	D3	C559	C5	L509	C5	R407	C2	R590	D5
C409	D3	C560	C5	L510	D4	R408	C3	R591	D5
C410	D3	C561	C5	Q301	A3	R409	D3	R592	D5
C411	D3	C562	C5	Q401	C4	R410	D3	R595	C1
C412	D3	C563	C5	Q402	B3	R411	D3	RB101	D2
C413	D3	C564	C5	Q407	B4	R412	C3	RB102	C1
C414	D3	C565	D5	Q408	A4	R413	B4	RB502	C1
C415	D3	C566	D5	Q503	C1	R414	B4	ZD102	D2
C416	D3	C567	D5	Q504	C1	R415	B3	ZD104	D2
C417	D3	C568	D5	Q505	C1	R416	B3	ZD105	D2
C418	D4	C569	D5	Q506	C1	R442	D2	ZD303	B2
C419	D4	C570	D5	Q507	C2	R447	B4	ZD304	B2
C420	C4	C571	D5	Q508	C1	R448	B4	ZD305	A3
C421	C4	C572	D5	R162	D2	R501	C4	ZD401	B4
C422	C3	C573	D5	R163	D2	R502	C4		
C423	C3	C574	C5	R165	A3	R503	D4		
C424	C3	C575	D5	R301	A1	R504	D4		

PCB LAYOUT - BOTTOM VIEW

6 - 5

6 - 5

C1001 C4	C1012 B4	C1023 B3	C121 D3	C157 B4	C303 A3	C346 A3	C420 C2	C516 D2	C546 C1	C582 A1	C614 A4	C829 D4	C853 D3	D506 A2	R118 C4	R182 C3	R522 B2	R533 A2	R832 D4	ZD604 A4
C1002 D4	C1013 B4	C1025 C2	C122 C3	C160 B4	C304 A3	C401 C3	C421 C2	C518 D2	C547 C1	C583 A2	C615 A4	C831 D4	C854 D3	D510 A1	R119 C4	R184 D3	R523 B2	R534 A2	R833 D4	
C1003 D4	C1015 C4	C1026 B4	C125 C3	C162 B4	C305 B3	C402 C3	C422 C2	C522 D2	C550 C2	C584 A2	C616 A4	C835 D4	C855 D3	FB101 C4	R124 C3	R3012 C3	R524 B2	R535 A2	R844 D4	
C1004 C4	C1016 C4	C1027 D2	C127 C4	C180 D3	C306 B3	C403 C3	C423 C2	C523 D2	C555 B2	C585 A2	C803 C4	C844 D4	C856 D3	FB103 D3	R125 C3	R321 A4	R525 A1	R591 B2	ZD101 B4	
C1005 B4	C1017 C4	C103 C4	C128 C4	C182 D3	C319 B4	C404 C3	C424 C3	C525 C1	C556 B2	C586 A2	C807 C4	C845 D3	C857 D3	FB113 A4	R127 C4	R507 B1	R526 A2	R592 C2	ZD106 D3	
C1006 C4	C1018 D3	C105 D3	C131 C4	C183 D3	C320 B4	C405 C3	C425 C3	C530 B1	C557 C2	C587 A2	C808 C4	C847 C4	D401 C3	FB116 B4	R146 A4	R508 C1	R527 A2	R620 B4	ZD107 D3	
C1007 C3	C1019 D4	C111 D3	C133 C4	C185 C4	C329 A4	C407 C3	C426 C2	C531 B1	C558 C2	C605 B4	C809 C4	C848 C4	D501 A1	R106 D3	R147 A4	R515 B1	R528 A2	R803 C4	ZD108 A3	
C1008 C4	C102 C4	C112 D3	C134 C4	C186 D4	C330 A4	C414 C2	C5000 A2	C532 C1	C569 B2	C607 B4	C810 C4	C849 C4	D502 A2	R112 D3	R151 B4	R516 C1	R529 A2	R808 C4	ZD109 A3	
C1009 C4	C1020 D2	C118 D3	C135 C4	C195 D2	C334 A4	C415 C2	C5001 A2	C533 C1	C570 B2	C609 B4	C811 C4	C850 D3	D503 A2	R113 D3	R153 B4	R519 B2	R530 A2	R822 D4	ZD601 A4	
C101 C4	C1021 C2	C119 D3	C136 C4	C301 A3	C337 B3	C416 C2	C5002 A2	C544 B1	C571 C2	C612 B4	C815 C4	C851 D3	D504 A2	R114 D3	R159 C4	R520 C2	R531 A1	R824 C4	ZD602 A4	
C1010 C3	C1022 B4	C120 D3	C142 D4	C302 A3	C339 B3	C419 C3	C5003 A2	C545 B1	C572 C2	C613 A4	C817 D4	C852 D3	D505 A2	R117 C4	R160 D3	R521 B2	R532 A1	R825 C3	ZD603 A4	

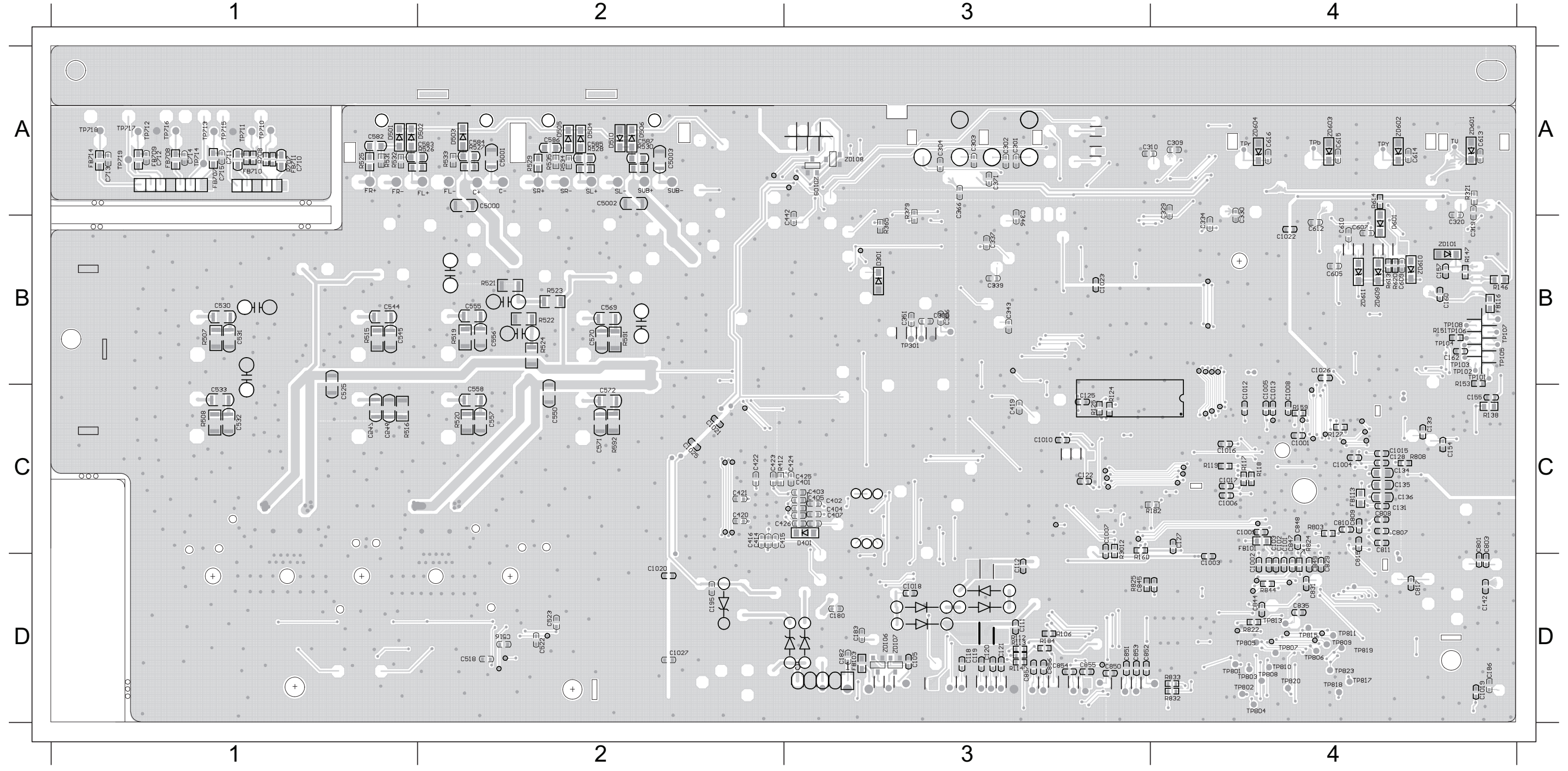

POWER BOARD

TABLE OF CONTENTS

Internal IC Diagram7-1
 Circuit Diagram.....7-2
 PCB Layout - Top View7-3
 PCB Layout - Bottom View7-4

7-1
INTERNAL IC DIAGRAM - AP3843GMTR

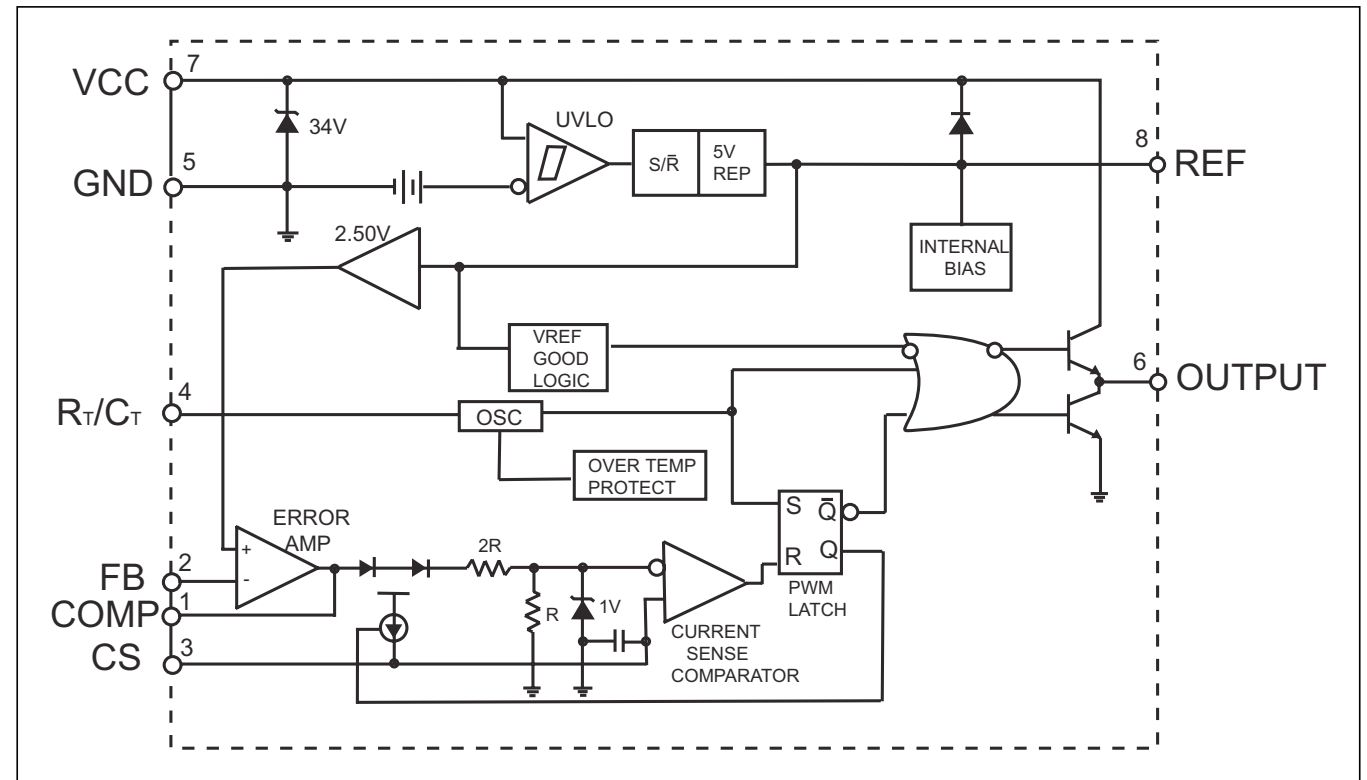

INTERNAL IC DIAGRAM - KA7500C

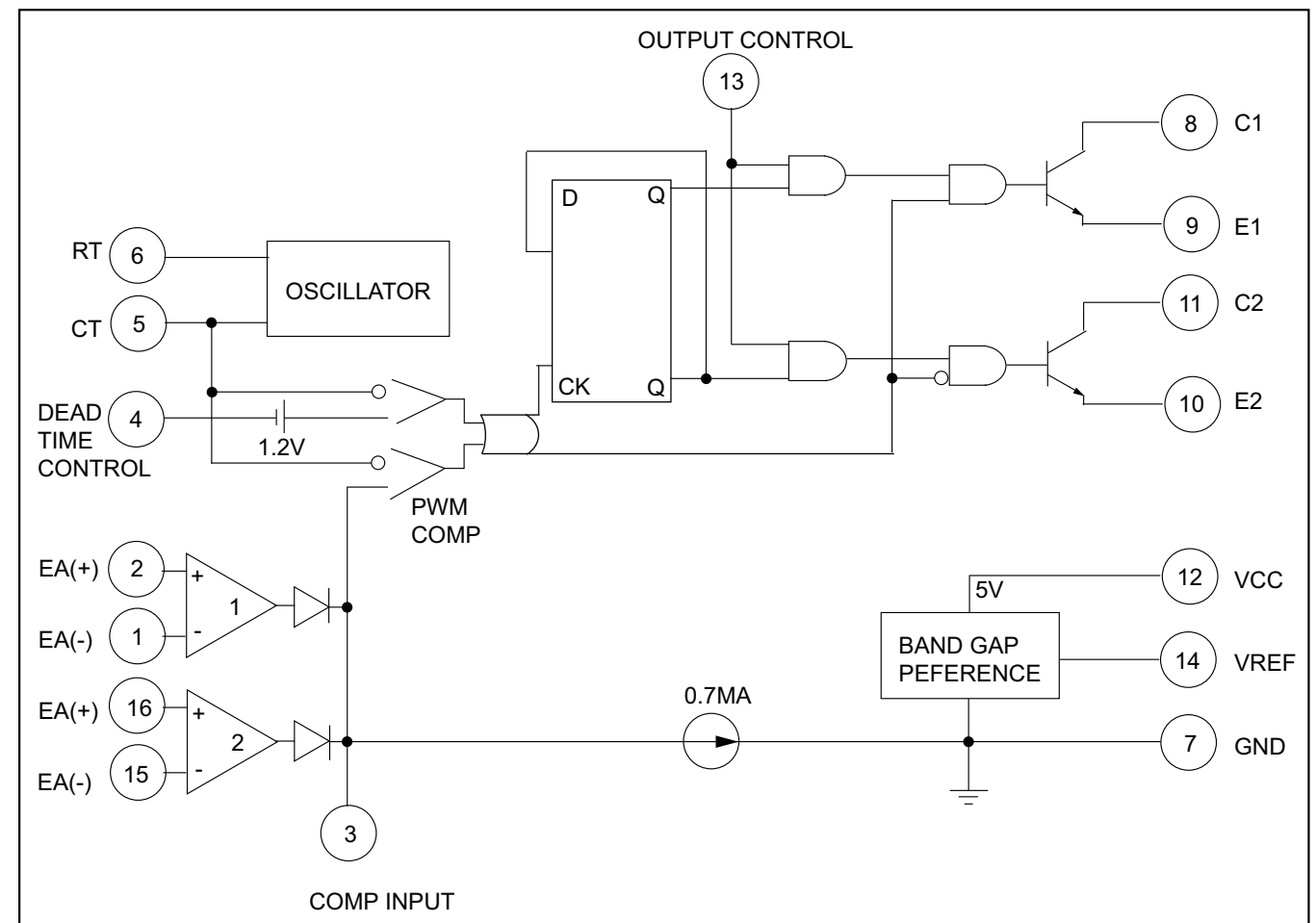

CIRCUIT DIAGRAM

BD901	A1	C915	C1	C926	D3	C937	C3	C948	C3	C960	C3	C972	A3	C985	D1	D904	B2	D916	B2	GT902	B2	L907	A3	Q912	B2	R907	C2	R922	D3	R935	C2	R946	C2	R959	C3	R970	A4	R982	A4	ZD902	C2
C901	D1	C916	C1	C927	C3	C938	B3	C949	A3	C961	C3	C973	D4	C992	B3	D905	B2	D917	C3	IC901	C1	L908	A3	Q913	A2	R908	C1	R925	D3	R936	C2	R947	D4	R960	A4	R971	A3	R983	D1	ZD903	B2
C902	D1	C917	B1	C928	C3	C939	C2	C950	A2	C962	C3	C974	B4	C993	B3	D906	A2	D918	C2	IC903	D2	NTC901	C1	Q914	C3	R909	A3	R926	B3	R937	C2	R948	C4	R961	C4	R972	A3	R984	D2	ZD904	A2
C903	D1	C918	B1	C929	C3	C940	D3	C951	A3	C963	C3	C975	C4	C994	D1	D907	B3	D919	C3	IC904	D3	Q902	C1	Q915	D4	R911	C4	R927	D2	R938	C3	R949	A2	R962	C3	R973	A3	R985	C3	ZD905	A3
C904	A1	C919	B1	C930	B4	C941	C2	C952	A2	C964	C4	C977	D1	CN901	D1	D908	B3	D922	C3	IC905	C4	Q903	D1	Q916	D2	R912	B1	R928	D2	R939	C3	R950	A2	R963	B3	R974	A3	R986	B4	ZD906	C4
C905	A1	C920	A1	C931	C3	C942	C2	C954	D3	C965	C3	C978	B1	CN903	D4	D909	B3	D923	C3	L901	C1	Q905	D3	R901	C1	R914	B1	R929	D2	R940	C2	R951	A2	R964	B3	R975	A3	R987	D1	ZD907	B4
C906	D1	C921	A1	C932	C3	C943	B2	C955	C3	C966	B3	C980	C4	CN904	C4	D910	A3	D924	A3	L902	B1	Q907	D2	R902	C1	R915	A1	R930	C2	R941	B2	R954	D3	R965	B3	R976	A3	T901	C2	ZD908	A4
C909	D1	C922	D2	C933	C2	C944	A2	C956	C3	C967	B3	C981	C4	CN905	A4	D911	A3	D927	C4	L903	D4	Q908	D2	R903	C1	R916	A1	R931	C2	R942	B2	R955	D3	R966	B3	R977	D4	T902	B2	ZD909	A4
C910	C1	C923	D2	C934	C2	C945	C1	C957	A3	C968	A3	C982	D1	CN907	B4	D912	A4	D928	B4	L904	C3	Q909	D2	R904	C1	R917	A1	R932	C2	R943	B2	R956	C3	R967	B3	R978	D4	T903	A2	ZD910	A4
C913	C1	C924	D3	C935	C2	C946	A2	C958	A4	C969	A3	C983	D1	D902	D2	D914	A4	D929	D1	L905	C3	Q910	B3	R905	C1	R918	A1	R933	C2	R944	A2	R957	C3	R968	B3	R979	C4	TVR901	C1	ZD911	D2
C914	C2	C925	D3	C936	B2	C947	C3	C959	C3	C971	A3	C984	D1	D903	B2	D915	C3	F901	C1	L906	B3	Q911	B3	R906	C2	R920	C2	R934	C2	R945	A3	R958	C3	R969	B4	R980	C4	ZD901	D2	ZD913	A3

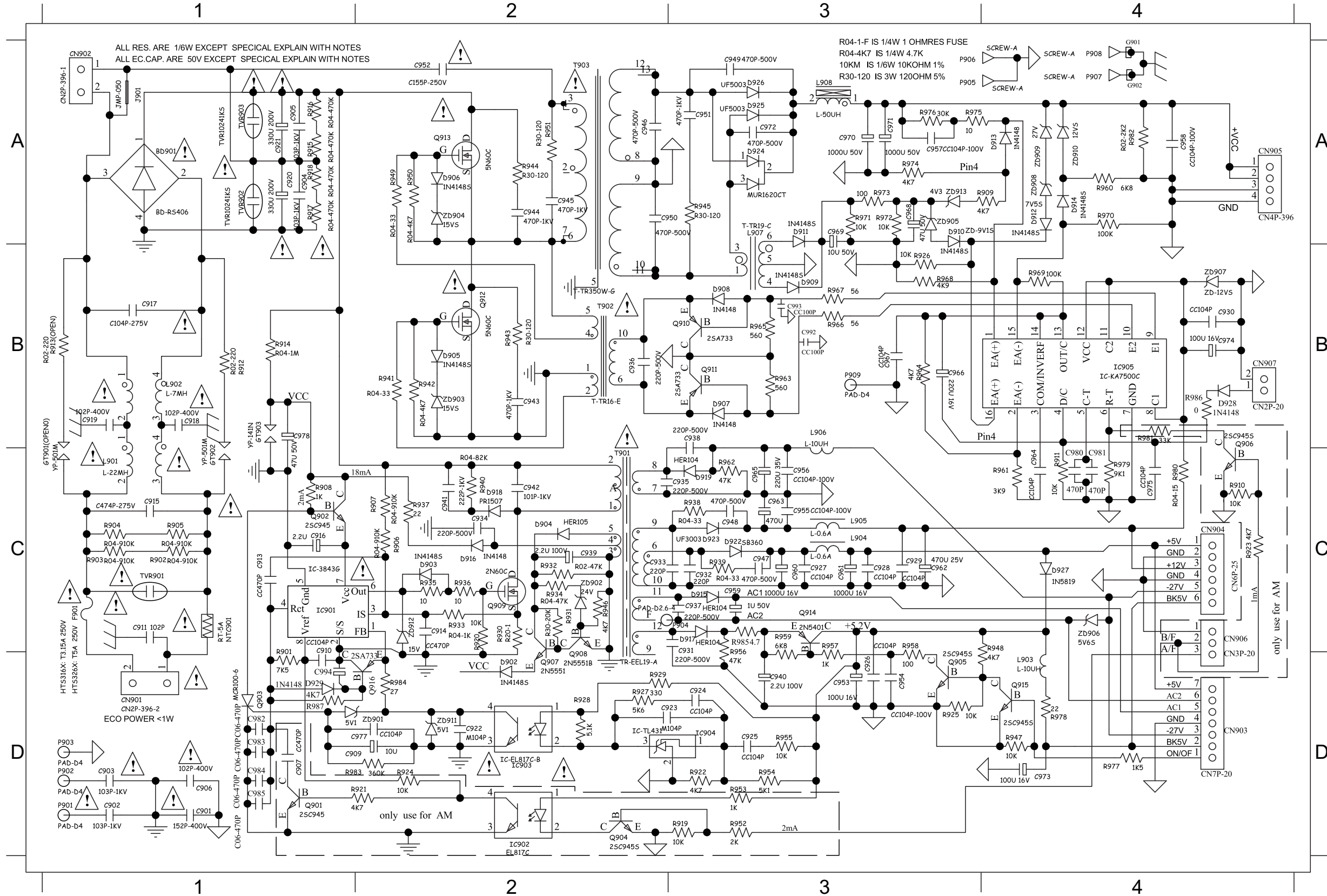

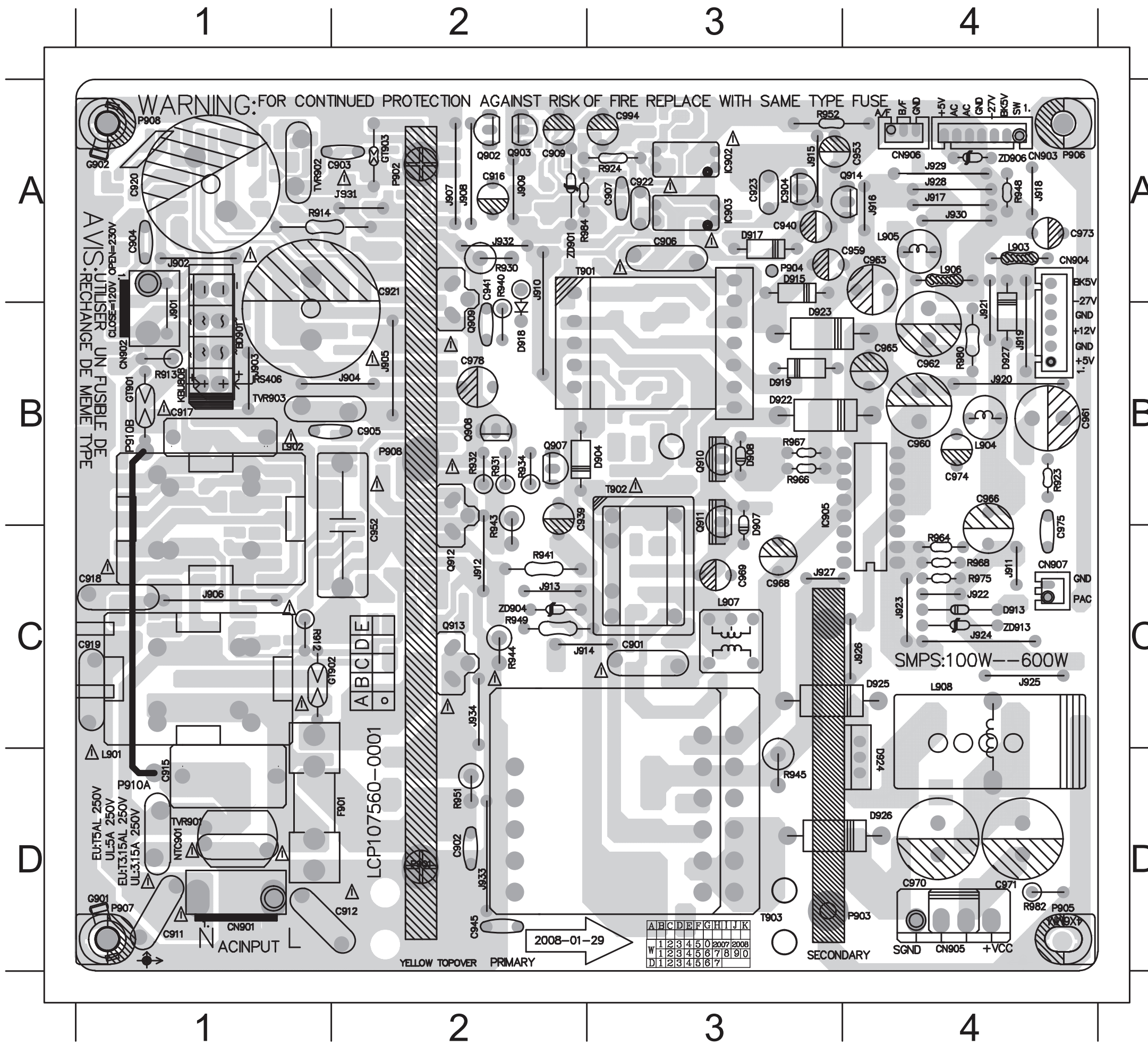

BD901	B1	IC903	A3	R914	A1
C901	C3	IC904	A3	R930	A2
C902	D2	IC905	B3	R931	B2
C903	A2	J901	A1	R932	B2
C904	A1	J902	A1	R934	B2
C905	B2	J903	B1	R940	A2
C906	A3	J904	B2	R941	C2
C909	A2	J905	B2	R943	C2
C915	D1	J906	C2	R944	C2
C916	A2	J907	A2	R945	D3
C917	B1	J908	A2	R948	A4
C918	C1	J909	A2	R949	C2
C919	C1	J910	A2	R951	D2
C920	A1	J911	C4	R964	C4
C921	A2	J912	C2	R966	B3
C922	A3	J913	C2	R967	B3
C923	A3	J914	C2	R968	C4
C939	B2	J915	A3	R975	C4
C940	A3	J916	A4	R980	B4
C941	A2	J917	A4	R982	D4
C945	D2	J918	A4	R984	A2
C952	C2	J920	B4	T901	A2
C959	A4	J921	B4	T902	B3
C960	B4	J922	C4	T903	D3
C961	B4	J923	C4	TVR901	D1
C962	B4	J924	C4	ZD901	A2
C963	B4	J925	C4	ZD904	C2
C965	B4	J926	C4	ZD906	A4
C966	B4	J927	C3	ZD911	A2
C968	C3	J929	A4	ZD913	C4
C969	C3	J930	A4		
C971	D4	J931	A2		
C973	A4	J932	A2		
C974	B4	J933	D2		
C975	B2	J934	D2		
C978	B2	L901	D1		
C994	A3	L902	B1		
CN901	D1	L903	A4		
CN903	A4	L904	B4		
CN904	A4	L905	A4		
CN905	D4	L906	A4		
CN907	C4	L907	C3		
D904	B3	L908	C4		
D907	B3	NTC901	D1		
D908	B3	Q902	A2		
D915	A3	Q903	A2		
D917	A3	Q907	B2		
D918	B2	Q908	B2		
D919	B3	Q909	B2		
D922	B3	Q910	B3		
D923	B3	Q911	B3		
D924	D4	Q912	C2		
D927	B4	Q913	C2		
F901	D2	Q914	A4		
GT902	C2	R912	C1		

PCB LAYOUT - BOTTOM VIEW

7-4

7-4

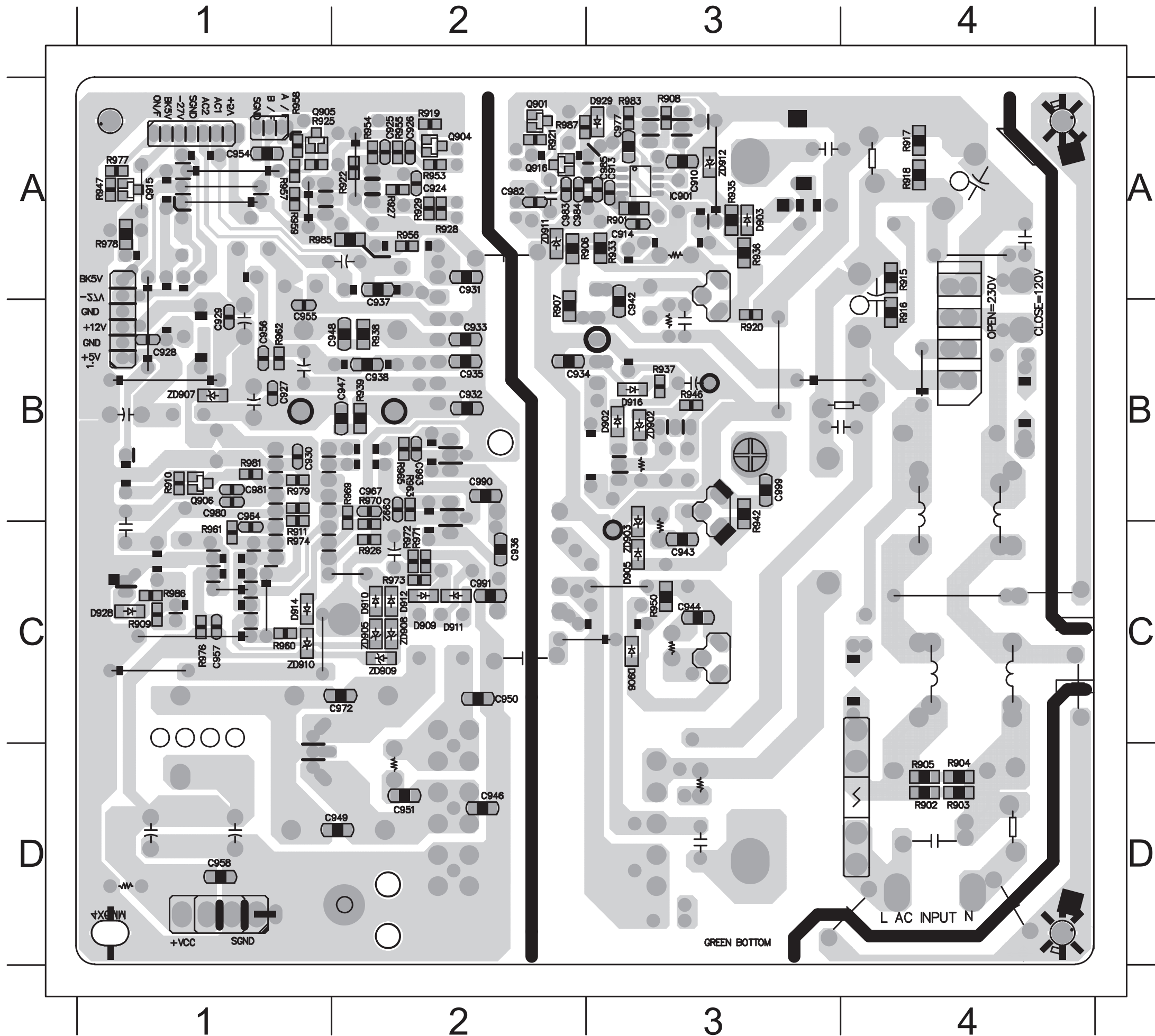

C910	A3	R903	D4
C913	A3	R904	D4
C914	A3	R905	D4
C924	A2	R906	A2
C925	A2	R907	A2
C926	A2	R908	A3
C927	B1	R909	C1
C928	B1	R911	C1
C929	B1	R915	A4
C930	B1	R916	B4
C931	A2	R917	A4
C932	B2	R918	A4
C933	B2	R920	B3
C934	B2	R922	A2
C935	B2	R925	A1
C936	C2	R926	C2
C937	A2	R927	A2
C938	B2	R928	A2
C942	A3	R929	A2
C943	C3	R933	A3
C944	C3	R935	A3
C946	D2	R936	A3
C947	B2	R937	B3
C948	B1	R938	B2
C949	D1	R939	B2
C950	C2	R942	B3
C951	D3	R946	B3
C954	A1	R947	A1
C955	B1	R950	C3
C956	B1	R954	A2
C957	C1	R955	A2
C958	D1	R956	A2
C964	B1	R957	A1
C967	B2	R958	A1
C972	C1	R959	A1
C977	A3	R960	C1
C980	B1	R961	C1
C981	B1	R962	B1
C982	A2	R963	B2
C983	A2	R965	B2
C984	A2	R969	B2
C985	A3	R970	B2
C992	B2	R971	C2
C993	B2	R972	C2
D902	B3	R973	C2
D903	A3	R974	C1
D905	C3	R976	C1
D906	C3	R977	A1
D909	C2	R978	A1
D910	C2	R979	B1
D911	C2	R983	A3
D912	C2	R985	A1
D914	C1	R986	C1
D916	B3	R987	A2
D928	C1	ZD902	B3
D929	A3	ZD903	C3
IC901	A3	ZD905	C2
Q905	A1	ZD907	B1
Q915	A1	ZD908	C2
Q916	A2	ZD909	C2
R901	A3	ZD910	C1
R902	D4		

MECHANICAL EXPLODED VIEW

8 - 1

8 - 1

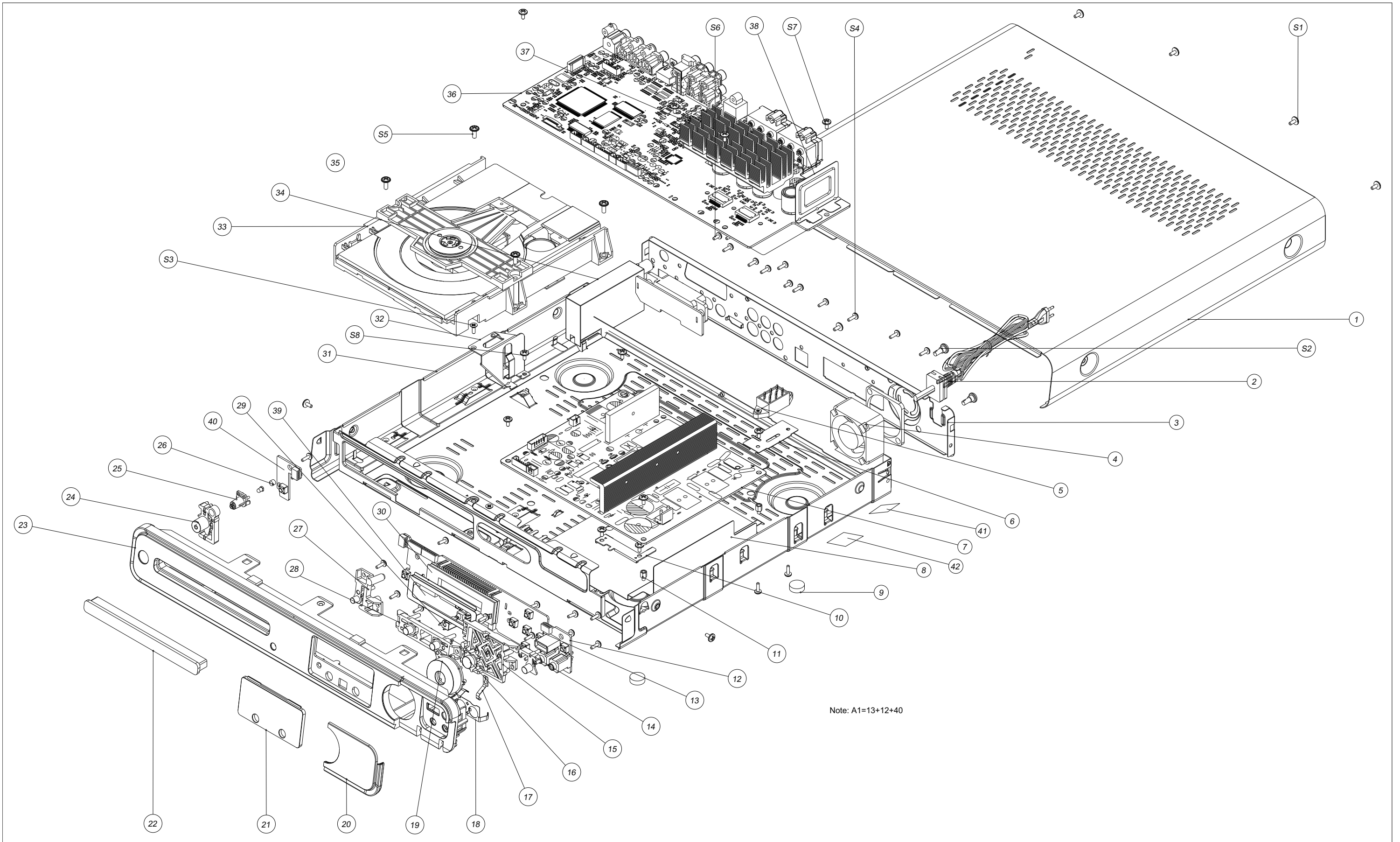

MECHANICAL PART LIST

Loc.	Part No.	Description
MAIN		
1	996510013764	TOP COVER SECC
2	996510001252	PWR CORD
3	996510013765	REAR COVER SECC
4	996510012461	FAN DC
7	996510015624	POWER PCB ASSY
8	996510011276	POWER PCB PLATE PVC
9	996510011288	RUBBER FOOT
15	996510011285	FUNCTION BUTTON BASE ABS
16	996510011284	SOURCE BUTTON ABS
19	996510011282	FUNCTION BUTTON ABS
20	996510011287	CONNECTORS COVER
21	996510011286	VFD LENS PMMA
22	996510013762	DVD DOOR ABS
23	996510013763	FRONT PANEL
24	996510011280	POWER BUTTON ABS
25	996510010840	STANDBY LENS
27	996510011281	EJECT BUTTON ABS
28	996510011283	VOLUME BUTTON ABS
31	996510013766	BOTTOM COVER SECC
33	996510017573	DVD LOADER
34	996510017572	TUNERPACK
36	996510019107	MAIN+SCART PCB ASSY
41	996510012456	PVC SHEET_SAFETY
42	996510011277	PVC SHEET-SMALL
A1	996510015626	VFD+JACK+STANDBY
DOCK	996510010855	SIMPLE IPOD DOCK
FM	996510008251	FM ANT
RC	996510010856	REMOTE CONTROL
V1	996510007429	FFCCBLE 10P
VIDEO	996500013058	RCA CABLE 2P 1.2M

SPEAKER

RFC	996510001599	RUBBER FOOT -CENTER SPK
RFFR	996510001601	RUBBER FOOT - REAR SPK
RFS	996510010854	RUBBER FOOT -SUB
SPKC	996510019108	SPEAKER BOX -CENTER
SPKFL	996510019109	SPEAKER BOX - FRONT LEFT
SPKFR	996510019110	SPEAKER BOX - FRONT RIGHT
SPKRL	996510019111	SPEAKER BOX - REAR LEFT
SPKRR	996510019112	SPEAKER BOX - REAR RIGHT
SUBW	996510019113	SUBWOOFER

REVISION LIST

9 - 1

9 - 1

Version 1.0
*Initial release